



US006581851B1

(12) **United States Patent**  
**Murphy**

(10) **Patent No.:** **US 6,581,851 B1**  
(45) **Date of Patent:** **Jun. 24, 2003**

- (54) **VAPOR RECOVERY NOZZLE**
- (76) Inventor: **Michael J. Murphy**, 3048 Root Ave., Carmichael, CA (US) 95608
- (\*) Notice: Subject to any disclaimer, the term of this patent is extended or adjusted under 35 U.S.C. 154(b) by 23 days.

4,079,761 A	*	3/1978	Herbst, Sr.	141/198
4,553,574 A	*	11/1985	Le Donne	141/286
4,667,710 A		5/1987	Wu	
4,834,151 A		5/1989	Law	
5,076,333 A		12/1991	Law	
5,249,611 A		10/1993	Law	
5,406,994 A		4/1995	Mitchell	
5,419,378 A		5/1995	Law	
5,507,328 A		4/1996	Donovan	

- (21) Appl. No.: **09/843,551**
- (22) Filed: **Apr. 25, 2001**
- (51) **Int. Cl.<sup>7</sup>** ..... **B67C 3/00**
- (52) **U.S. Cl.** ..... **239/272; 239/271; 239/589; 239/590; 239/590.3; 239/590.5; 141/198; 141/59; 141/285**
- (58) **Field of Search** ..... **239/271, 272, 239/569, 589, 590, 590.3, 590.5; 141/2, 4, 7, 59, 94, 192, 198, 285, 290, 291, 301, 350, 351, 352, 353, 354**

\* cited by examiner

*Primary Examiner*—Robin O. Evans  
(74) *Attorney, Agent, or Firm*—Heisler & Associates

(57) **ABSTRACT**

A nozzle is provided which includes a nozzle body having a proximal end and an insertion end and defining an inlet orifice at the proximal end thereof and an outlet orifice at the insertion end thereof. The nozzle body is adapted to be attached at the proximal end thereof to an opening of a container and to be inserted at the insertion end thereof into an opening of a receiving vessel for dispensing a first fluid from the container into the receiving vessel from the inlet orifice to the outlet orifice thereof. The nozzle further includes a venting device connected to the nozzle body and defining a vent discharge opening for venting a second fluid from the receiving vessel into the container through the vent discharge opening such that the second fluid is vented through the vent discharge opening of the venting device without traversing the first fluid in the container substantially during an entire time for a dispensing of the first fluid from the container into the receiving vessel.

- (56) **References Cited**
- U.S. PATENT DOCUMENTS**
- 2,628,759 A \* 2/1953 Bodendoerfer ..... 141/293
- 2,723,070 A 11/1955 Merriam
- 2,724,535 A \* 11/1955 Day et al. .... 141/275
- 2,746,663 A \* 5/1956 Day et al. .... 141/59
- 2,761,606 A \* 9/1956 Pahl et al. .... 141/140
- 3,160,183 A \* 12/1964 Franz ..... 141/291
- 3,181,576 A 5/1965 Pellerino
- 3,626,996 A \* 12/1971 Bingham et al. .... 141/5
- 3,799,222 A 3/1974 Franz
- 3,848,645 A \* 11/1974 Franz ..... 141/117

**32 Claims, 3 Drawing Sheets**

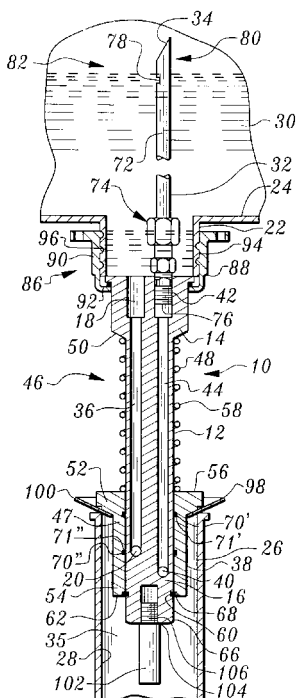

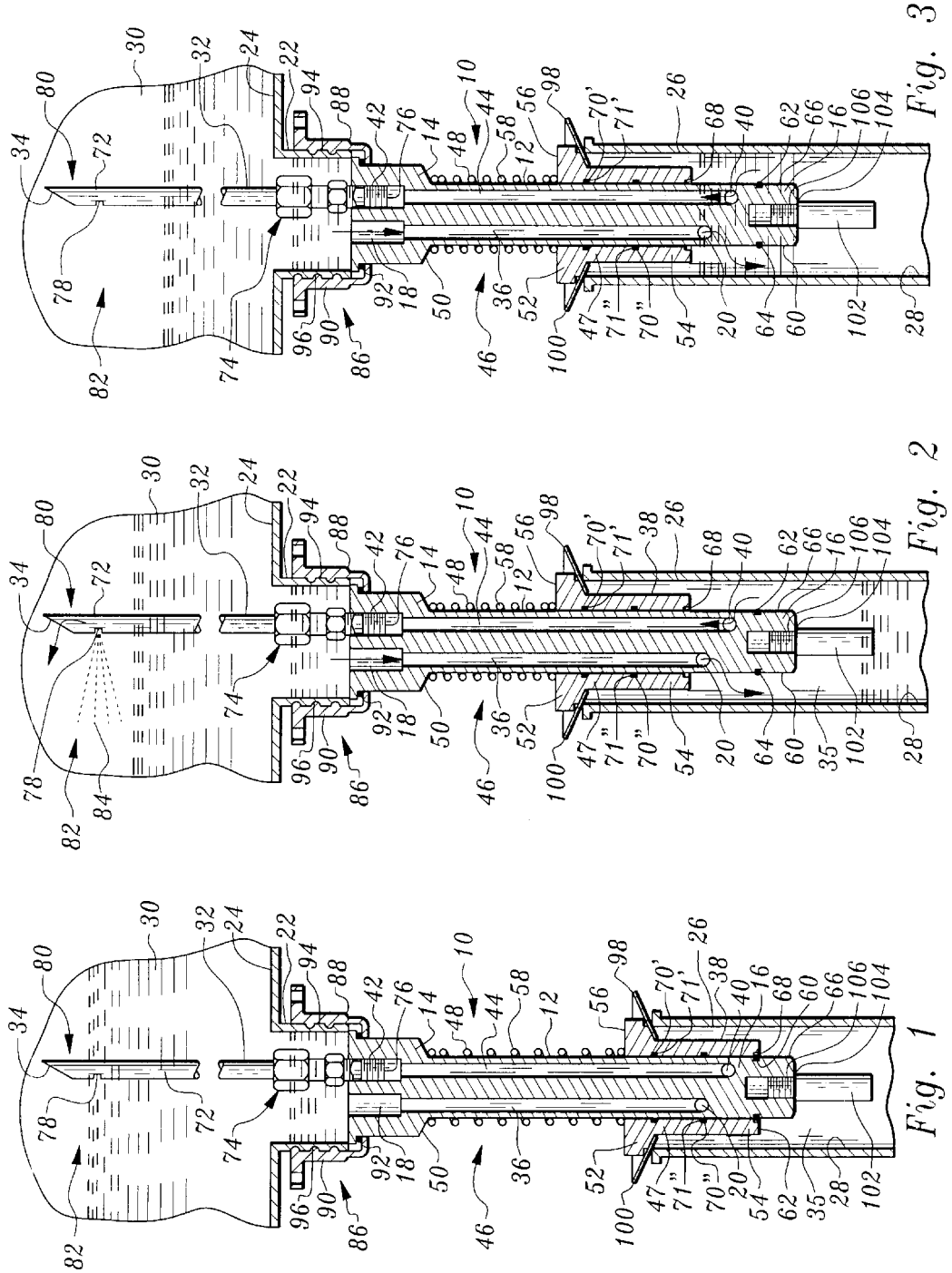



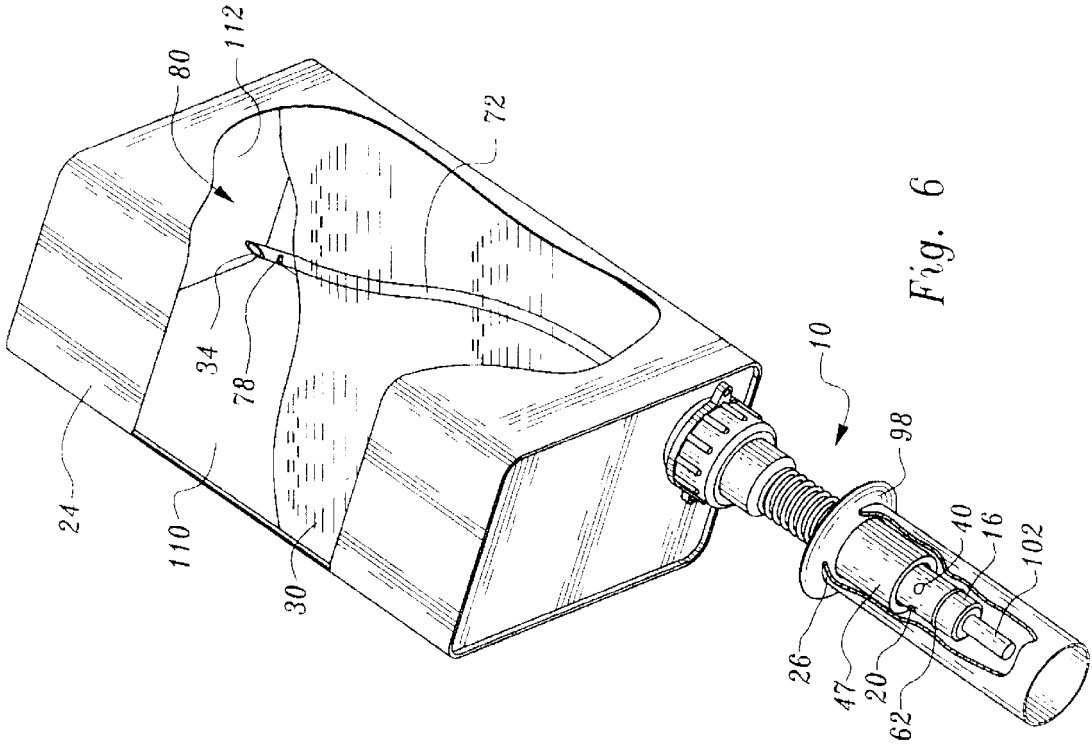

Fig. 6

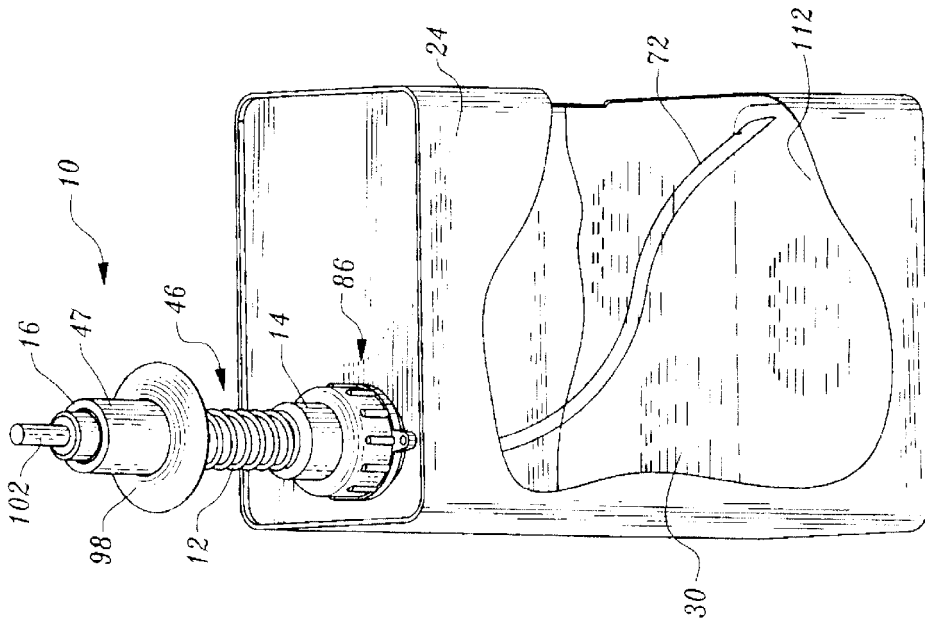

Fig. 5

## VAPOR RECOVERY NOZZLE

## FIELD OF THE INVENTION

This invention generally relates to nozzles for containers of fluid, and more particularly to nozzles that permit transfers of the fluid under the influence of gravity into a receiving vessel without the risk of spills, overflow or vapor escape.

## BACKGROUND OF THE INVENTION

Nozzles of the general type described above are known in the art. These prior art nozzles generally have, as one objective, to minimize spills or splashes while they are dispensing fluid from a portable container into a receiving vessel (i.e. a fuel tank) while at the same time stopping the flow of fluid when the receiving vessel is full. Examples of such nozzles are provided in U.S. Pat. No. 2,723,070, U.S. Pat. No. 3,181,576, U.S. Pat. No. 3,799,222, U.S. Pat. No. 4,667,710, U.S. Pat. No. 4,834,151, U.S. Pat. No. 5,076,333, U.S. Pat. No. 5,249,611, U.S. Pat. No. 5,406,994, U.S. Pat. No. 5,419,378, U.S. Pat. No. 5,507,328, the contents of which are incorporated herein by reference.

There are numerous instances where a receiving vessel or tank must be filled with a fluid. Typically, in such instances, it is necessary that spills and vapor release be minimized or totally eliminated by virtue of the environment where the dispensing is accomplished or by virtue of the fluid being dispensed, such as where fuel is being dispensed into the fuel tanks of lawn mowers, chain saws, tractors, motorized recreational vehicles, outboard motors, personal water craft and other fuel-powered machinery. In such instances, it is undesirable that any fuel should be spilled or vapor released, given the posed health and environmental hazards associated with such spills.

Spills occur in a variety of circumstances. For instance, containers of fluid must usually be tilted toward the receiving vessel with their opening pointing downward in order for fluid to be dispensed. Spills are not uncommon during such tilting. Additionally, spills tend to occur when the receiving vessel becomes full and overflows. This is especially true because, if an automatic stop mechanism is not provided on the nozzle, it is difficult to see when the receiving vessel has been actually filled. Moreover, the improper venting of the portable container can also contribute to spills. For instance, improper venting can result in an uneven flow of fluid including surges of flow, making impossible a reliable prediction of the fluid level in the receiving vessel, tending to cause splashes, and generally resulting in turbulence in the container that makes it difficult to hold the container steady.

Although the prior art has, up till now, attempted to address the above problems, it has, however, failed to offer a nozzle that effectively prevents spills and overflow of the receiving vessel while at the same time advantageously having a simple and effective configuration allowing a speedy dispensing of fluid from a container into the receiving vessel.

## SUMMARY OF THE INVENTION

The invention provides a nozzle including a nozzle body having a proximal end and an insertion end and defining an inlet orifice at the proximal end thereof and an outlet orifice at the insertion end thereof. The nozzle body is adapted to be attached at the proximal end thereof to an opening of a

container and to be inserted at the insertion end thereof into an opening of a receiving vessel for dispensing a first fluid from the container into the receiving vessel from the inlet orifice to the outlet orifice thereof. The nozzle further includes a vapor/air venting device connected to the nozzle body and defining a vent discharge opening for venting a second fluid (typically a gaseous fluid such as fuel vapor or air) from the receiving vessel into the container through the vent discharge opening. The second fluid is vented through the vent discharge opening of the venting device without traversing the first fluid in the container substantially during an entire time for dispensing of the first fluid from the container into the receiving vessel.

The nozzle further comprises a valve head disposed at the insertion end of the nozzle body for selectively opening and closing the outlet orifice of the nozzle body. The valve head includes a flexible seal adapted to be compressed to sealingly abut against walls of the opening of the receiving vessel when the nozzle body is inserted into the opening of the receiving vessel for substantially preventing at least the second fluid (i.e. vapor/air/volatile organic compounds or VOCs) from escaping at the opening of the receiving vessel.

The invention further provides a method for using the nozzle as described above, the method comprising the steps of dispensing a first fluid from a container into a receiving vessel; and venting a second fluid from the receiving vessel into the container such that the second fluid is vented into the receiving vessel without traversing the first fluid in the container substantially during an entire time for a dispensing of the first fluid from the container into the receiving vessel.

Additionally, the invention provides a kit for forming a nozzle. The kit includes a nozzle body having a proximal end and an insertion end and defining an inlet orifice at the proximal end thereof, an outlet orifice at the insertion end thereof, the nozzle body further being adapted to be attached at the proximal end thereof to an opening of a container and to be inserted at the insertion end thereof into an opening of a container for dispensing a first fluid from the container into the receiving vessel from the inlet orifice to the outlet orifice. The kit further includes a venting device adapted to be connected to the nozzle body and defining a vent discharge opening for venting a second fluid from the receiving vessel into the container through the vent discharge opening such that the second fluid is vented through the vent discharge opening of the venting device without traversing the first fluid in the container substantially during dispensing of the first fluid from the container into the receiving vessel.

Furthermore, the invention provides a combination comprising a container defining an opening, and a nozzle attached to the container at the opening thereof. The nozzle comprises a nozzle body having a proximal end and an insertion end and defining an inlet orifice at the proximal end thereof and an outlet orifice at the insertion end thereof, the nozzle body further being attached at the proximal end thereof to the opening of the container and to be inserted at the insertion end thereof into an opening of a receiving vessel for dispensing a first fluid from the container into the receiving vessel from the inlet orifice of the nozzle body to the outlet orifice of the nozzle body. The nozzle further comprises a venting device connected to the nozzle body and defining a vent discharge opening for venting a second fluid from the receiving vessel into the container through the vent discharge opening such that the second fluid is vented through the vent discharge opening of the venting device without traversing the first fluid in the container (i.e. without needing to bubble up through a substantial portion of the first fluid) substantially during an entire time for a dispensing of the first fluid from the container into the receiving vessel.

The invention additionally provides a nozzle comprising means for dispensing a first fluid from a container into a receiving vessel; and means for venting a second fluid from the receiving vessel into the container such that the second fluid is vented into the receiving vessel without traversing the first fluid in the container substantially during an entire time for a dispensing of the first fluid from the container into the receiving vessel.

Further scope of applicability of the present invention will become apparent from the detailed description given hereinafter. However, it should be understood that the detailed description and specific examples, while indicating preferred embodiments of the invention, are given by way of illustration only, since various changes and modifications within the spirit and scope of the invention will become apparent to those skilled in the art from this detailed description.

### BRIEF DESCRIPTION OF THE DRAWINGS

The present invention will become more fully understood from the detailed description given hereinbelow and the accompanying drawings which are given by way of illustration only, and thus are not limitative of the present invention, and wherein:

FIG. 1 is a cross sectional view of the nozzle and container combination of this invention depicting the nozzle as having been inserted into the opening of a receiving vessel;

FIG. 2 is a view similar to FIG. 1, depicting the valve head as having been slid back to open the outlet orifice and vent inlet orifice of the nozzle for dispensing fluid between the container and the receiving vessel;

FIG. 3 is a view similar to FIGS. 1 and 2, showing the fluid level in the receiving vessel as having reached the vent inlet orifice of the nozzle body for shutting off the supply of fluid into the receiving vessel;

FIG. 4 is an exploded view of a kit for making a preferred embodiment of the nozzle according to the present invention;

FIG. 5 is a perspective, partially cut-away view of a nozzle and container combination according to a preferred embodiment of the present invention; and

FIG. 6 is a view similar to FIG. 5, depicting the container as having been tilted and the nozzle as having been inserted into the opening of a receiving vessel for dispensing fluid from the container into the receiving vessel.

### DESCRIPTION OF THE PREFERRED EMBODIMENT

According to the present invention, a nozzle is provided allowing the dispensing a first fluid from a portable container into a receiving vessel. The nozzle also allows the venting of a second fluid from the receiving vessel into the portable container. The second fluid is vented from the receiving vessel into the portable container without traversing the first fluid in the container substantially during dispensing of the first fluid from the container into the receiving vessel. According to the present invention, the first fluid may be a liquid, such as a liquid hydrocarbon fuel, and the second fluid may be a gas such as air and fuel vapors. The portable container may further be a can of fuel and the receiving vessel a fuel tank. The invention encompasses within its scope the use of a nozzle with any containers, receiving vessels and/or fluids that would allow the operation of the nozzle as described above.

Turning now to the drawings, and, more particularly, to FIGS. 1, 2 and 3, the present invention provides, as shown in the combination of nozzle and receiving vessel according to a preferred embodiment of the present invention, a nozzle 10 including a nozzle body 12 having a proximal end 14 and an insertion end 16. An inlet orifice 18 is provided at the proximal end 14 thereof and an outlet orifice 20 at the insertion end thereof. The nozzle body 12 is further shown as having been attached at the proximal end 14 thereof to an opening 22 of a container 24 and as having been inserted at the insertion end 16 thereof into an opening 26 of a receiving vessel 28 (such as a pipe leading to a fuel tank) for dispensing a first fluid 30 from the container 24 into the receiving vessel 28 from the inlet orifice 18 to the outlet orifice 20 thereof.

A venting device 32 is connected to the nozzle body 12 and defines a vent discharge opening 34 for venting a second fluid 35 from the receiving vessel 28 into the container 24 through the vent discharge opening 34 such that the second fluid is vented through the vent discharge opening of the venting device without traversing the first fluid 30 in the container substantially during dispensing of the first fluid from the container into the receiving vessel. For maximum benefit, the vent discharge opening 34 is deep within the container 24 and spaced from the proximal end 14 of the nozzle body 12 a distance similar to a depth of the container when inverted for emptying. However, some benefit is still obtained with the vent discharge opening 34 closer to but still spaced from the nozzle body 12, with this spacing preferably more than half the distance from the container opening to an opposite wall. In this way, the benefits of keeping the second fluid separate from the first fluid are provided for a majority of the time that the container is being emptied. Advantageously, such an arrangement of the venting device allows a speedy venting of the second fluid into the container, this way reducing dispensing time and further providing a smooth delivery of the first fluid into the receiving vessels substantially without surges or appreciable turbulence associated with requiring the second fluid 35 to "bubble up" through the first fluid 30 within the container 24.

The nozzle body 12 preferably defines a pathway 36 therein between the inlet orifice 18 and the outlet orifice 20 for dispensing the first fluid from the container 24 into the receiving vessel 28 through the pathway 36. A valve head 38 is shown as having been disposed at the insertion end 16 of the nozzle body 12 for selectively opening and closing the outlet orifice 20 and a vent inlet orifice 40 of the nozzle body 12. Vent inlet orifice 40 is at the proximal end 16 of the nozzle body 12, the nozzle body 12 further being configured for allowing the second fluid 35 to be vented from the receiving vessel 28 to the container 24 from the vent inlet orifice 40 of the nozzle body 12 to the vent discharge opening 34 of the venting device 32. The nozzle body 12 further defines a vent outlet orifice 42 and a pathway 44 therein between the vent inlet orifice 40 and the vent outlet orifice 42 for dispensing the second fluid 35 from the receiving vessel 28 into the container 24 through the pathway 44. Preferably, the vent inlet orifice 40 is disposed closer to the insertion end 16 of the nozzle body 12 than the outlet orifice 42. It is noted that, while the preferred embodiment of the present invention shown in the figures depicts a single outlet orifice and a single outlet orifice for the first fluid, and a single vent discharge opening and a single vent inlet orifice for the second fluid, the present invention includes within its scope the provision of a plurality of each of the above orifices and of a plurality of vent discharge openings depending on application needs.

Preferably, the valve head **38** comprises a retractable cover mechanism **46** including a retractable cover **47** in the form of a sleeve telescopically disposed over the nozzle body **12** to slidably cover and uncover the outlet orifice **20** and the vent inlet orifice **40** of the nozzle body **12** for selectively closing and opening each of the outlet orifice **20** and the vent inlet orifice **20**. The retractable cover mechanism **46** according to the present invention can take any form in order to allow the selective covering and uncovering of the orifices of the nozzle body **12** as described above, in a manner that would be readily recognized by one skilled in the art. Preferably, the retractable cover mechanism **46** according to the present invention comprises a biasing mechanism **48** disposed to bias the retractable cover **47** in a default mode thereof to close the outlet orifice **20** and the vent inlet orifice **40** of the nozzle **10** by covering the outlet orifice **20** and the vent inlet orifice **40** of the nozzle body **12**. The biasing mechanism **48** is further actuatable to effect a sliding of the cover **47** into an actuated mode thereof to open the outlet orifice **20** and the vent inlet orifice **40** of the nozzle **10**. The default mode of the retractable cover **47**, as described above and as shown in FIG. 1, advantageously prevents any spilling or leaking of the first fluid **30** out of the container **24** when the container is being tilted and before the nozzle **10**, including the outlet orifice **20** of the nozzle body **12** and the vent inlet orifice **40** thereof, are inserted into the opening **26** of the receiving vessel **28**. Substantially no amount of the first fluid **30** emerges from the nozzle **10** until the insertion end **16** of the nozzle body **12** is in the opening **26**, and until the retractable cover **47** has been actuated, as shown in FIG. 2, by pressing against the opening **26** and compressing the biasing mechanism **48**, to expose and open the outlet orifice **20** and vent inlet orifice **40** of the nozzle body within receiving vessel **28**.

According to a more preferred embodiment of the present invention, the retractable cover mechanism **46** operates through cooperation with corresponding structural configurations of the nozzle body **12**. In particular, as shown in FIGS. 1, 2 and 3, the nozzle body **12** defines a reference step **50** at the proximal end **14** thereof, and the retractable cover **47** has a first end **52** and a second end **54** and further defines a reference step **56** at the first end **52** thereof. The biasing mechanism **48** comprises a helical compression spring **58** abutting, at one end thereof, the reference step **50** of the nozzle body **12**, and at another end thereof the reference step **56** of the retractable cover **47** for providing a compliant preload between the nozzle body **12** and the retractable cover **47**. The function of the compliant preload provided by compression spring **58** is to urge, in a default state thereof, the retractable cover **47** to cover the outlet orifice **20** and vent inlet orifice **40** of the nozzle body **12** and to be compliant for being compressed, as shown in FIG. 2, to open the above orifices.

More preferably, the nozzle body defines at the insertion end **16** thereof an annular recess **60** for receiving an O-ring **62** therein. O-ring **62** is part of the retractable cover mechanism **46**, and has an outer perimeter **64**, as best seen in FIGS. 2 and 3, and is disposed in the annular recess of **60** the nozzle body **12** such that the outer perimeter thereof juts out from an outer surface **66** of the nozzle body **12**. Moreover, the retractable cover **47** preferably defines an O-ring step **68** at the first end thereof, the O-ring step being adapted to abut against the outer perimeter **64** of the O-ring when the retractable cover is in its default mode as shown in FIG. 1, the outer perimeter **64** of the O-ring thereby providing a stop element against a further advance of the retractable cover **47** toward the insertion end **16** of the nozzle body.

According to a further preferred aspect of the present invention, the retractable cover mechanism **46** further comprises O-rings **70'** and **70''**, and the retractable cover **47** defines corresponding annular recesses **71'** and **71''** therein, each respective O-ring being disposed in a corresponding one of the recesses of the retractable cover. While the figures show two O-rings **70'** and **70''**, it is noted that the invention includes within its scope the use of one or any other number of O-rings as described above. The O-rings **70'** and **70''** stabilize the retractable cover **47** on the nozzle body **12** and provide a seal for substantially preventing the fluids from escaping from the container **24** or the receiving vessel **28** through the retractable cover **47**. The second fluid **36**, such as air or fuel vapors or a mixture of both could possibly escape from the receiving vessel **28** once the nozzle has been inserted into the opening **26** thereof, the escape occurring among other places through the annular space existing between the sleeve valve or retractable cover **47** and the exterior surface **66** of nozzle body **12**. Escape of the second fluid from this annular space, however, is substantially prevented through the use of one or more O-rings or other seals, such as O-rings **70'** and **70''**. O-rings **70'** and **70''** further act as guides in the above annular space for the retractable cover **47**, in particular during its movement from its default position as shown in FIG. 1 into its actuated position as shown in FIG. 2. While the O-rings **70'** and **70''** are shown set in grooves in the retractable cover **47**, they could alternatively be set in grooves in the nozzle body **12**.

According to a further, preferred embodiment of the present invention, the venting device **32** comprises an elongated tube **72**, the tube preferably having at one end thereof a fastening mechanism **74** adapted to fasten the tube **72** to the vent outlet orifice **42** of the nozzle body **12**. Fastening mechanism **74** may take any suitable form, such as, in the preferred form thereof, that of a threaded bolt configured to be threaded into a corresponding threaded neck portion **76** of the vent outlet opening **42** of nozzle body **12**. Preferably, the venting device **32** includes a sound generating mechanism **78** at the tip **80** thereof adapted to generate a sound during a venting of the second fluid into the container, as suggested by way of example in FIG. 2. The sound generating mechanism may, according to the present invention, take any form, as readily recognizable by one skilled in the art. Preferably, the sound generating mechanism **78** comprises a whistle **82** for generating a sound by virtue of at least a portion **84** of the second fluid being vented into the container through the whistle **82**, as seen in FIG. 2. Advantageously, the whistle **82** allows an audible indication of dispensing time for the first fluid, the halting of the audible indication signaling the user to remove the nozzle **10** from the opening **26** of the receiving vessel **28**. As seen in the figures, the vent discharge opening **34** is defined at the tip **80** of the elongated tube, the tip further being non-perpendicular with respect to a centerline of the elongated tube, as best seen in FIGS. 1, 2 and 3. The provision of a tip at which the vent discharge opening is defined and which is non-perpendicular to the tube center line as described above advantageously allows the elongated tube **72** to be placed in the container such that, even where the tip **80** is disposed adjacent a wall of the container, a discharge of the second fluid is substantially ensured.

According to a preferred embodiment, the nozzle **10** according to the present invention further includes an attachment mechanism **86** coupled to the nozzle body **12** for attaching the nozzle body **12** to the opening **22** of the container **24**. The attachment mechanism **86** according to the present invention may take any suitable form, as readily recognizable by one skilled in the art. Preferably, the attach-

ment mechanism 86 is configured for sealingly attaching the nozzle body 12 to the opening 22 of the container 24 for substantially preventing the first fluid 30 and the second fluid 36 from escaping at the opening 22 of the container 24. For effecting the above sealing attachment, preferably, the proximal end 14 of the nozzle body 12 defines a flange 88, and the attachment mechanism 86 comprises a cap ring 90 and a cap ring seal 92. The cap ring 90 is preferably threaded on inner walls 94 thereof for attachment to corresponding threads 96 on the opening 22 of the container 24. As seen in FIGS. 1 through 3, the cap ring seal 92 abuts at one side thereof against the cap ring 90 and on another side thereof against the flange 88 of the proximal end 14 of the nozzle body 12, the cap ring seal and the cap ring being effective for providing a sealed attachment of the nozzle 10 to the opening 22 of the container 24 for substantially preventing the first fluid 30 and the second fluid 35 from escaping at the opening 22 of the container 24.

Preferably, the valve head is configured for a sealing insertion thereof into the opening 26 of the receiving vessel 28 for substantially preventing at least the second fluid 35 from escaping at the opening 26 of the receiving vessel 28. For effecting the above result, the valve head preferably includes a flexible seal 98, preferably made of rubber, and adapted to be compressed as seen in FIGS. 1 through 3 and in FIG. 6, to sealingly abut against walls of the opening 26 of the receiving vessel 28 for substantially preventing at least the second fluid 35 from escaping at the opening 26 of the receiving vessel 28. As depicted in the figures, the seal 98 is preferably generally conical, with its wide portion 100 oriented toward the proximal end 14 of the nozzle body 12. The seal 98 thus rests against the first end 52 of the cover 47 and seals with the opening 26 before the cover 47 is retracted and fluid transfer commences.

Preferably, a tip element 102 is disposed at the insertion end 16 of the nozzle body 12, the tip element 102 being configured for advantageously pushing open a covering of the opening of the receiving vessel when the nozzle body is being inserted therein (i.e. pushing open a vapor valve on an automotive fuel tank fill pipe). More preferably, tip element may be threaded into the insertion end 16 of the nozzle body 12 as shown, such as through a threaded portion 106 on the tip element engaging a corresponding threaded neck hole 104 of the nozzle body 12.

Referring now to FIG. 4, an exploded view of the nozzle 10 according to the present invention is provided. The exploded view depicts the nozzle 10 as having been taken apart, and essentially represents a kit for forming a nozzle 10 according to the preferred embodiment of the present invention depicted in FIGS. 1, 2 and 3. The kit according to the present invention includes the nozzle body 12 including proximal end 14 and insertion end 16, and defining the inlet orifice 18 (FIG. 1) at the proximal end 14 thereof and the outlet orifice 20 at the insertion end 16 thereof. The nozzle body 12 is adapted to be attached at the proximal end 14 thereof to the opening 22 of the container 24 and to be inserted at the insertion end 16 thereof into an opening 26 of a receiving vessel 28 for dispensing a first fluid 30 from the container 24 into the receiving vessel 28 from the inlet orifice 18 to the outlet orifice 20.

The kit further includes the venting device 32 adapted to be connected to the nozzle body 12, such as by fastening mechanism 74, and defining the vent discharge opening 34 for venting the second fluid 36 from the receiving vessel 28 into the container 24 through the vent discharge opening 34 such that the second fluid 35 is vented through the vent discharge opening 34 of the venting device 32 without

traversing the first fluid 30 in the container 24 substantially during an entire time for a dispensing of the first fluid 30 from the container 24 into the receiving vessel 28. Preferably the kit further includes the valve head 38 including the retractable cover 47 adapted to be disposed at the insertion end 16 of the nozzle body 12 for selectively opening and closing the outlet orifice 20. More preferably, the nozzle 10 includes the attachment mechanism 86 adapted to be connected to the nozzle body 12 for attaching the nozzle body 12 to the opening 22 of the container 24.

As seen in FIG. 4, the complete kit according to the preferred embodiment of the present invention comprises the venting device 32, including elongated tube 72 defining vent discharge opening 34 at the tip thereof, and including fastening mechanism 74. The nozzle body 12 further defines a flange 88 at the proximal end 14 thereof for supporting O-ring 92 thereon, and an annular recess 60 at the insertion end 16 thereof for receiving O-ring 62 therein. The insertion end 16 of the nozzle body 12 further defines the threaded opening 104 therein for receiving the corresponding threaded end portion 106 of tip element 102 therein for attaching the tip element to the nozzle body, and a reference step 50 for the compression spring 58. The retractable cover mechanism includes retractable cover 47 having first end 52 and second end 54, and further defining an O-ring step 68 for O-ring 62, and the reference step 56. Additionally, the two O-rings 70' and 70" are adapted to be received in corresponding grooves (FIG. 1) in the retractable cover 47. Seal 98 additionally is adapted to be received on reference surface 56 of retractable cover 47, and to receive the cover 47 in a central opening 108 thereof. The kit as shown in FIG. 4, when assembled, would yield the nozzle 10 according to the preferred embodiment of the present invention as depicted in FIGS. 1 through 3.

In operation, the preferred embodiment of the nozzle 10 according to the present invention is used by dispensing the first fluid 30 from the container 24 into the receiving vessel 28, and by venting the second fluid 35 from the receiving vessel 28 into the container 24, such that the second fluid 36 is vented into the container 24 without traversing the first fluid 30 in the container 24 substantially during dispensing of the first fluid 30 from the container 24 into the receiving vessel 28.

Referring to FIGS. 5 and 6, the container 24 and nozzle 10 combination shown therein is first tilted, and the nozzle 10 inserted into the opening 26 of receiving vessel 28, as shown in FIG. 1. Here, the retractable cover 47 is in its default mode, covering orifices 20 and 40 of the nozzle body thereby substantially preventing spills during and after the inversion of the container 24 and the insertion of the nozzle 10 into the opening 26 of the receiving vessel 28. Thereafter, the container 24 is pressed down such that spring 58 on the nozzle 10 is compressed by virtue of the retractable cover 47 being slid away from orifices 20 and 40. Once the outlet orifice 20 is exposed, the first fluid 30 begins being dispensed into receiving vessel 28 through inlet orifice 18, pathway 36 and outlet orifice 40.

More precisely, the vent inlet orifice 40, being closer to the insertion end 16, is first uncovered. The associated second fluid 35 pathway inside the nozzle 10 is typically initially full of the first fluid 30. When the vent inlet orifice 40 is opened the weight of the first fluid 30 causes backfill of the first fluid 30 out of the vent inlet orifice 40 and into the receiving vessel 28. Typically, this back flow occurs until the second fluid 35 pathway is cleared of the first fluid 30. Next, the first fluid 30 begins to flow out of the outlet orifice 20 of the nozzle 10.

After an initial period during which the first fluid 30 is being dispensed into the receiving vessel 28 through the outlet orifice 20 without any of the second fluid 35, such as air and/or vapors being admitted into the container 24, the pressure of the second fluid 35 in the container 24 is sufficiently reduced and the pressure of the second fluid in the receiving vessel is sufficiently increased to clear the tube 72 of any possible remaining liquids and induce a venting of the second fluid 35 from the receiving vessel 28 through vent inlet orifice 40, pathway 44, vent outlet orifice 42, venting tube 72 and vent discharge opening 34 of the venting device 32. This second fluid pathway 44 can be considered a "venting path," a "vent," a "route," or a "venting device," with these terms not limited only to the specific structure disclosed, but rather to describe any appropriate structure capable of carrying the second fluid 35 from the receiving vessel 28 to the container 24.

Preferably, a sound is generated during venting of the second fluid 35 into the container 24, such as by the provision of the whistle 82 at the tip 80 of elongated venting tube 72. The venting device 32 in this way allows an even-flowing transfer of the first fluid 30 from the container 24 into the receiving vessel 28. Advantageously, because the tip 80 of elongated venting tube 72 is disposed in a pocket 110 of the second fluid 35 in the container, the second fluid 35 is vented into the receiving vessel 28 without traversing the first fluid 30 in the container 24 substantially during an entire time for a dispensing of the first fluid 30 from the container 24 into the receiving vessel 28.

The venting, as shown in FIG. 2, continues, until the level of the first fluid 30 in the receiving vessel 28 is such that it covers vent inlet orifice 40 and outlet orifice 20 of nozzle body 12, thus halting the flow of both fluids between the container 24 and the receiving vessel 28. Where, as shown in FIGS. 1 through 3, the vent inlet orifice 40 is disposed further toward the insertion end 16 of the nozzle body 12 than the outlet orifice 20, the whistling through whistle 78 stops just before the first fluid stops flowing into the receiving vessel. Also, the fluid flow is stopped with the level of the first fluid 30 sufficiently below the opening 26 into the receiving vessel 28 to keep the first fluid 30 from spilling out of the opening 26 when the nozzle 10 is removed or the first fluid 30 expands (i.e. due to heating) within the receiving vessel 28.

Attachment mechanism 86, including O-ring 92, allows a sealing attachment of the nozzle body 12 to the opening 22 of the container 24 for substantially preventing the first fluid 30 and the second fluid 36 from escaping at the opening 22 of the container 24. Additionally, seal 98, preferably made of rubber, is compressed when the nozzle 10 is inserted into the opening 26 of the receiving vessel 28, thereby allowing a sealing insertion of the nozzle 10 into the opening 26 of the receiving vessel 28 for substantially preventing at least the second fluid 36 from escaping at the opening 26 of the receiving vessel 28.

After the level of the first fluid 30 has reached the orifices 20 and 40 of the nozzle body 12, the nozzle 10 may be removed from the opening 26 of the receiving vessel 28, after which the retractable cover 47 is repositioned over the outlet orifice 20 and the vent inlet orifice 40 of the nozzle body 12 for closing the outlet orifice 20 and the vent inlet orifice 40 of the nozzle body 12 during the step of removing, thereby advantageously preventing further spills.

Referring now to FIGS. 5 and 6, a combination is shown of a container 24 such as a fuel container 24 to which a nozzle 10 according to the preferred embodiment of the

invention and described in relation to FIGS. 1 through 3 has been attached. FIG. 5 shows the container 24 as being upright, while FIG. 6 shows the container 24 as having been tilted and the nozzle 10 as having been inserted into opening 26 of the receiving vessel 28, a pushing forward of the container onto opening 26 having actuated retractable cover 47 to open outlet orifice 20 and vent inlet orifice 40 at the proximal end 16 of nozzle body 12. The elongated tube 72 is shown in FIGS. 5 and 6 as extending diagonally within the container 24 such that a free end or tip 80 of the elongated tube 72 is disposed at an inner edge 112 of the container. The above arrangement of the elongated tube 72 as shown in FIGS. 5 and 6 permits the second fluid 35, such as air and fuel vapors, to be vented from receiving vessel 28 into the container 24 almost always in a pocket 110 of the second fluid 35 in the container 24, such as in an air and vapor pocket, such that the second fluid 35 is vented into the container 24 without traversing the first fluid 30 in the container 24 substantially during an entire time for a dispensing of the first fluid 30 from the container 24 into the receiving vessel 28. Preferably, the elongated tube is made of a flexible material such as a polymeric hydrocarbon which does not degrade when in contact with typical hydrocarbon fuels, as is known in the art. Advantageously, the flexibility of the elongated tube 72 allows the same to bend over to an inner edge 112 of container 24 during an attachment of the nozzle 10 to the container 24 substantially without any further adjustments needing to be made to the elongated tube in order to position the same in the desired manner.

The present invention further includes within its scope a nozzle 10 comprising means for dispensing a first fluid 30 from a container 24 into a receiving vessel 28; and means for venting a second fluid 35 from the receiving vessel 28 into the container 24 such that the second fluid 35 is vented into the container 24 without traversing the first fluid 30 in the container 24, substantially during an entire time for a dispensing of the first fluid 30 from the container 24 into the receiving vessel 28, the above means being substantially shown and described in relation to FIGS. 1, 2, 3, 4 and 5 above.

This disclosure is provided to reveal a preferred embodiment of the invention and a best mode for practicing the invention. Having thus described the invention in this way, it should be apparent that various different modifications can be made to the preferred embodiment without departing from the scope and spirit of this disclosure. When structures are identified as a means to perform a function, the identification is intended to include all structures which can perform the function specified. Accordingly, it is intended by the appended claims to cover all modifications of the invention which fall within the true spirit and scope of the invention.

What is claimed is:

1. A nozzle comprising:

a nozzle body having a proximal end and an insertion end and defining an inlet orifice at the proximal end thereof and an outlet orifice at the insertion end thereof, the nozzle body further being adapted to be attached at the proximal end thereof to an opening of a container and to be inserted at the insertion end thereof into an opening of a receiving vessel for dispensing a first fluid from the container into the receiving vessel from the inlet orifice to the outlet orifice thereof;

a valve head disposed at the insertion end of the nozzle body for selectively opening and closing the outlet orifice of the nozzle body, the valve head comprising a

flexible seal adapted to be compressed to sealingly abut against walls of the opening of the receiving vessel when the nozzle body is inserted into the opening of the receiving vessel for substantially preventing at least a second fluid from escaping at the opening of the receiving vessel;

further comprising a venting device connected to the nozzle body and defining a vent discharge opening for venting the second fluid from the receiving vessel into the container through the vent discharge opening such that the second fluid is vented through the vent discharge opening of the venting device without traversing the first fluid in the container substantially during an entire time for a dispensing of the first fluid from the container into the receiving vessel;

the container to which the proximal end of the nozzle body is attached, being substantially rigid;

the container being closed other than through the nozzle; and

both the venting device for the second fluid and the inlet orifice for the first fluid communicating simultaneously with the container.

2. The nozzle according to claim 1, wherein the flexible seal is made of rubber.

3. The nozzle according to claim 1, wherein the venting device comprises an elongated tube.

4. A nozzle comprising:

a nozzle body having a proximal end and an insertion end and defining an inlet orifice at the proximal end thereof and an outlet orifice at the insertion end thereof, the nozzle body further being adapted to be attached at the proximal end thereof to an opening of a container and to be inserted at the insertion end thereof into an opening of a receiving vessel for dispensing a first fluid from the container into the receiving vessel from the inlet orifice to the outlet orifice thereof;

a venting path connected to the nozzle body and defining a vent discharge opening for venting a second fluid from the receiving vessel into the container through the vent discharge opening such that a second fluid is vented out of the receiving vessel through the vent discharge opening of the venting path without traversing the first fluid in the container substantially during an entire time for a dispensing of the first fluid from the container into the receiving vessel;

comprising an attachment mechanism coupled to the nozzle body for removably attaching the nozzle body to the opening of the container;

wherein the attachment mechanism is configured for removably sealingly attaching the nozzle body to the opening of the container for substantially preventing the first fluid and the second fluid from escaping at the opening of the container; and

wherein the proximal end of the nozzle body defines a flange, and the attachment mechanism comprises: a cap ring threaded on inner walls thereof for attachment to corresponding threads on the opening of the container, and a cap ring seal abutting at one side thereof against the flange of the proximal end of the nozzle body, the cap ring seal and the cap ring being effective for providing a sealed attachment of the nozzle to the opening of the container for substantially preventing the first fluid and the second fluid from escaping at the opening of the container.

5. A nozzle comprising:

a nozzle body having a proximal end and an insertion end and defining an inlet orifice at the proximal end thereof and an outlet orifice at the insertion end thereof, the nozzle body further being adapted to be attached at the proximal end thereof to an opening of a container and to be inserted at the insertion end thereof into an opening of a receiving vessel for dispensing a first fluid from the container into the receiving vessel from the inlet orifice to the outlet orifice thereof;

a valve head disposed at the insertion end of the nozzle body for selectively opening and closing the outlet orifice of the nozzle body, the valve head comprising a flexible seal adapted to be compressed to sealingly abut against walls of the opening of the receiving vessel when the nozzle body is inserted into the opening of the receiving vessel for substantially preventing at least a second fluid from escaping at the opening of the receiving vessel;

further comprising a venting device connected to the nozzle body and defining a vent discharge opening for venting the second fluid from the receiving vessel into the container through the vent discharge opening such that the second fluid is vented through the vent discharge opening of the venting device without traversing the first fluid in the container substantially during an entire time for a dispensing of the first fluid from the container into the receiving vessel; and

wherein the venting device comprises a sound generating mechanism thereon adapted to generate a sound during a venting of the second fluid into the container.

6. The nozzle according to claim 5, wherein the sound generating mechanism comprises a whistle for generating a sound by virtue of at least a portion of the second fluid being vented into the container through the whistle.

7. A nozzle comprising:

a nozzle body having a proximal end and an insertion end and defining an inlet orifice at the proximal end thereof and an outlet orifice at the insertion end thereof, the nozzle body further being adapted to be attached at the proximal end thereof to an opening of a container and to be inserted at the insertion end thereof into an opening of a receiving vessel for dispensing a first fluid from the container into the receiving vessel from the inlet orifice to the outlet orifice thereof;

a venting path connected to the nozzle body and defining a vent discharge opening for venting a second fluid from the receiving vessel into the container through the vent discharge opening such that a second fluid is vented out of the receiving vessel through the vent discharge opening of the venting path without traversing the first fluid in the container substantially during an entire time for a dispensing of the first fluid from the container into the receiving vessel;

the container being substantially rigid; the container being closed other than through the nozzle; and

both the venting path for the second fluid and the inlet orifice for the first fluid communicating simultaneously with the container.

8. The nozzle according to claim 7, wherein the nozzle body defines a pathway therein between the inlet orifice and the outlet orifice thereof for dispensing the first fluid from the container into the receiving vessel through the pathway.

9. The nozzle according to claim 7, further comprising a valve head disposed at the insertion end of the nozzle body for selectively opening and closing the outlet orifice of the nozzle body.

## 13

10. The nozzle according to claim 9, wherein the nozzle body defines a vent inlet orifice at the insertion end thereof and is configured for allowing the second fluid to be vented from the receiving vessel to the container from the vent inlet orifice of the nozzle body to the vent discharge opening of the venting path.

11. The nozzle according to claim 10, wherein the nozzle body further defines a vent outlet orifice and a pathway therein between the vent inlet orifice and the vent outlet orifice thereof for dispensing the second fluid from the receiving vessel into the container through the pathway.

12. The nozzle according to claim 10, wherein the vent inlet orifice of the nozzle body is disposed closer to the insertion end of the nozzle body than the outlet orifice thereof.

13. The nozzle according to claim 10, wherein at least one of the inlet orifice, the outlet orifice, the vent discharge opening and the vent inlet orifice comprises a plurality of openings.

14. The nozzle according to claim 10, wherein the valve head comprises a retractable cover mechanism including a retractable cover disposed to slidably cover and uncover the outlet orifice and the vent inlet orifice of the nozzle body for selectively closing and opening each of the outlet orifice and the vent inlet orifice of the nozzle.

15. The nozzle according to claim 14, wherein the retractable cover mechanism further comprises a biasing mechanism disposed to bias the retractable cover in a default mode thereof to close the outlet orifice and the vent inlet orifice of the nozzle by covering the outlet orifice and the vent inlet orifice of the nozzle, the biasing mechanism further being actuatable to effect a sliding of the cover into an actuated mode thereof to open the outlet orifice and the vent inlet orifice of the nozzle.

16. The nozzle according to claim 15, wherein:

the nozzle body defines a reference step at the proximal end thereof;

the retractable cover has a proximal end and an insertion end and further defines a reference step at the proximal end thereof;

the biasing mechanism comprises a helical compression spring abutting, at one end thereof, the reference step of the nozzle body, and at another end thereof the reference step of the retractable cover for providing a compliant preload between the nozzle body and the retractable cover.

17. The nozzle according to claim 14, wherein:

the nozzle body defines at the insertion end thereof an annular recess for receiving an O-ring therein;

the retractable cover mechanism further includes an O-ring having an outer perimeter and being disposed in the annular recess of the nozzle body such that the outer perimeter thereof juts out from an outer surface of the nozzle body; and

the retractable cover has a first end and a second end and defines an O-ring step at the first end thereof, the O-ring step being adapted to abut against the outer perimeter of the O-ring when the retractable cover is in its default mode, the outer perimeter of the O-ring thereby providing a stop element against an advance of the retractable cover toward the insertion end of the nozzle body.

18. The nozzle according to claim 14, wherein the retractable cover mechanism further comprises at least one O-ring; and the retractable cover defines at least one annular recess therein, each respective one of the at least one O-ring being disposed in a corresponding one of the at least one annular

## 14

recess of the retractable cover, the at least one O-ring being effective for stabilizing the retractable cover on the nozzle body and for providing a seal for substantially preventing at least the second fluid from escaping from the receiving vessel through the retractable cover.

19. The nozzle according to claim 7, wherein the first fluid is a liquid and the second fluid is a gas.

20. The nozzle according to claim 19, wherein the liquid is primarily a fuel and the gas includes air.

21. The nozzle according to claim 7, wherein the venting device comprises an elongated tube.

22. The nozzle according to claim 21, wherein the elongated tube is adapted to extend diagonally within the container such that a free end of the elongated tube is disposed at an inner edge of the container.

23. The nozzle according to claim 9, wherein the valve head is configured for a sealing insertion thereof into the opening of the receiving vessel for substantially preventing at least the second fluid from escaping at the opening of the receiving vessel.

24. The nozzle according to claim 23, wherein the valve head comprises a flexible rubber seal adapted to be compressed to sealingly abut against walls of the opening of the receiving vessel for substantially preventing at least the second fluid from escaping at the opening of the receiving vessel.

25. The nozzle according to claim 21, wherein the elongated tube includes a tip, the vent discharge opening being defined at the tip of the elongated tube, the tip further being non-parallel with respect to a centerline of the elongated tube.

26. The nozzle according to claim 7, further comprising an attachment mechanism coupled to the nozzle body for removably attaching the nozzle body to the opening of the container.

27. The nozzle according to claim 26, wherein the attachment mechanism is configured for removably sealingly attaching the nozzle body to the opening of the container for substantially preventing the first fluid and the second fluid from escaping at the opening of the container.

28. The nozzle according to claim 7, wherein at least one of the inlet orifice, the outlet orifice and the vent discharge opening comprises a plurality of openings.

29. The nozzle according to claim 7, further comprising a tip element removably attachable extending from the insertion end of the nozzle body, the tip element being configured for pushing open a covering of the opening of the receiving vessel when the nozzle body is being inserted therein.

30. A nozzle comprising:

a nozzle body having a proximal end and an insertion end and defining an inlet orifice at the proximal end thereof and an outlet orifice at the insertion end thereof, the nozzle body further being adapted to be attached at the proximal end thereof to an opening of a container and to be inserted at the insertion end thereof into an opening of a receiving vessel for dispensing a first fluid from the container into the receiving vessel from the inlet orifice to the outlet orifice thereof;

a venting path connected to the nozzle body and defining a vent discharge opening for venting a second fluid from the receiving vessel into the container through the vent discharge opening such that a second fluid is vented out of the receiving vessel through the vent discharge opening of the venting path without traversing the first fluid in the container substantially during an entire time for a dispensing of the first fluid from the container into the receiving vessel; and

15

wherein the venting path comprises a sound generating mechanism thereon adapted to generate a sound during a venting of the second fluid into the container.

31. The nozzle according to claim 30, wherein the sound generating mechanism comprises a whistle for generating a sound by virtue of at least a portion of the second fluid being vented into the container through the whistle. 5

32. A nozzle comprising:

a nozzle body having a proximal end and an insertion end and defining an inlet orifice at the proximal end thereof and an outlet orifice at the insertion end thereof, the nozzle body further being adapted to be attached at the proximal end thereof to an opening of a container and to be inserted at the insertion end thereof into an opening of a receiving vessel for dispensing a first fluid from the container into the receiving vessel from the inlet orifice to the outlet orifice thereof; 10 15

16

a venting path connected to the nozzle body and defining a vent discharge opening for venting a second fluid from the receiving vessel into the container through the vent discharge opening such that a second fluid is vented out of the receiving vessel through the vent discharge opening of the venting path without traversing the first fluid in the container substantially during an entire time for a dispensing of the first fluid from the container into the receiving vessel; and

wherein said venting path includes a vent inlet orifice at an end of said venting path closest to said insertion end of said nozzle body, said vent inlet orifice having a portion thereof most distant from the insertion end of the nozzle body closer to the insertion end of the nozzle body than a portion of the outlet orifice closest to the insertion end, of the nozzle body.

\* \* \* \* \*