



US00D505897S

(12) **United States Design Patent**
Wade

(10) **Patent No.:** **US D505,897 S**

(45) **Date of Patent:** **** Jun. 7, 2005**

(54) **EXTENDIBLE AUTOMOTIVE MIRROR**

(76) **Inventor:** **James T. Wade**, 7960 Eagle View La.,
Granite Bay, CA (US) 95746

(**) **Term:** **14 Years**

(21) **Appl. No.:** **29/198,910**

(22) **Filed:** **Feb. 5, 2004**

(51) **LOC (8) Cl.** **12-16**

(52) **U.S. Cl.** **D12/188**

(58) **Field of Search** D12/187-189;
359/830-856, 864-881; 248/475.1, 476

(56) **References Cited**

U.S. PATENT DOCUMENTS

D397,072 S	*	8/1998	Hellhake et al.	D12/187
D449,261 S	*	10/2001	Englander	D12/187
D456,330 S	*	4/2002	Wade	D12/187
D459,685 S	*	7/2002	Huang	D12/187
D472,504 S	*	4/2003	Leveille	D12/187
D479,169 S	*	9/2003	Schmidt et al.	D12/187

* cited by examiner

Primary Examiner—Melody N. Brown

(74) *Attorney, Agent, or Firm*—Heisler & Associates

(57) **CLAIM**

The ornamental design for an extendible automotive mirror, as shown and described.

DESCRIPTION

FIG. 1 is a perspective view of the extendible automotive mirror;

FIG. 2 is a right side view of the invention;

FIG. 3 is a top plan view of the invention;

FIG. 4 is a rear elevation view of the invention;

FIG. 5 is a front elevation view of the invention;

FIG. 6 is a bottom plan view of the invention;

FIG. 7 is a left side view of the invention;

FIG. 8 is a perspective view of the invention in an expanded configuration;

FIG. 9 is a rear elevation view of the invention in an expanded configuration; and,

FIG. 10 is a top plan view of the invention in an expanded configuration.

The broken lines in FIGS. 1, 4, 6, 8 and 9 are for purposes of illustration only and form no part of the claimed design.

1 Claim, 4 Drawing Sheets

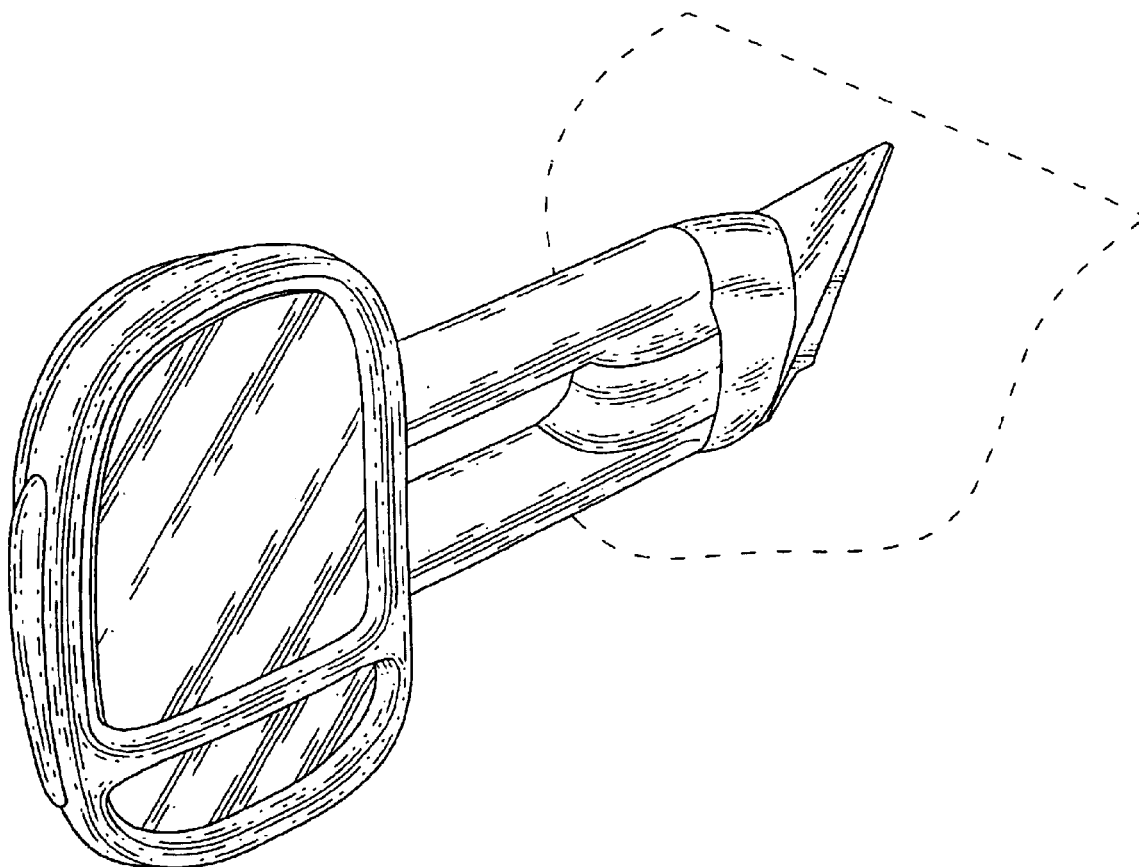

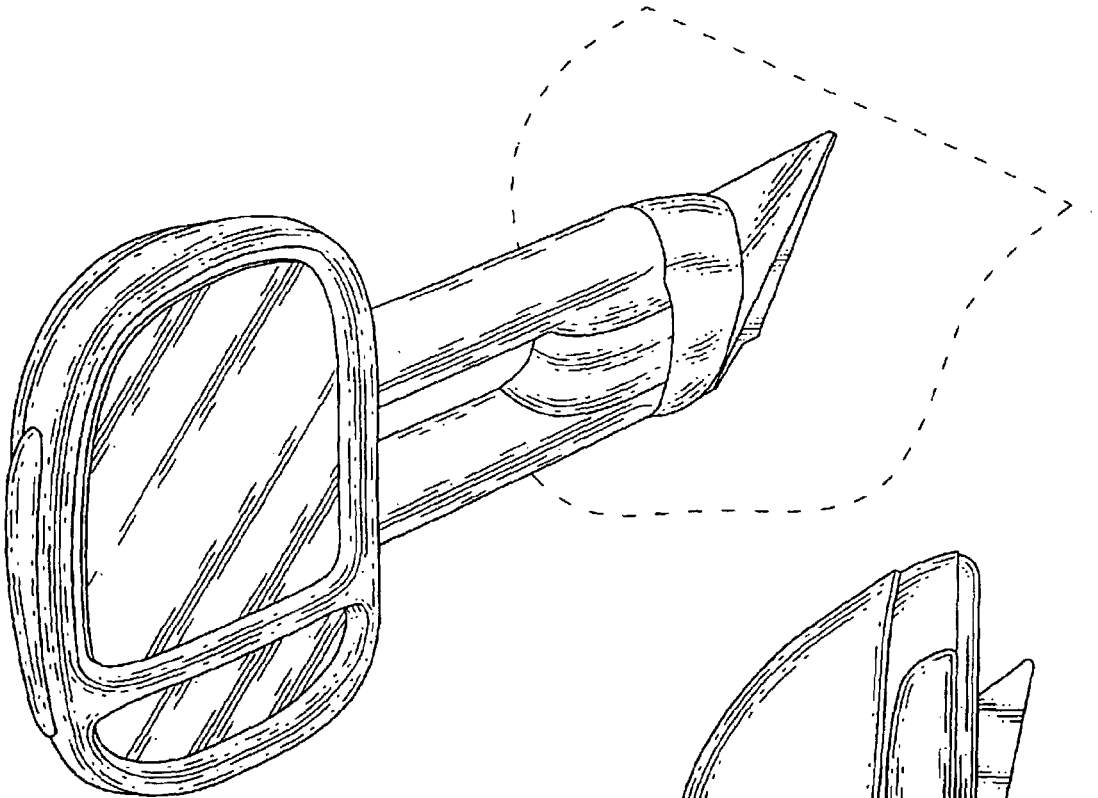

Fig. 1

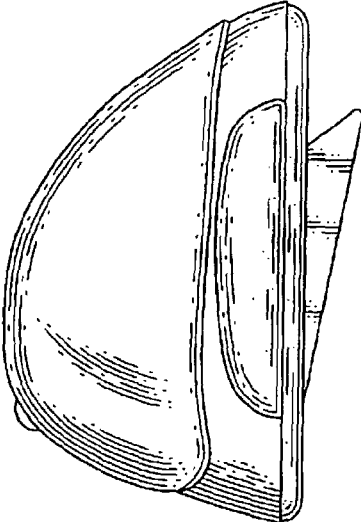

Fig. 2

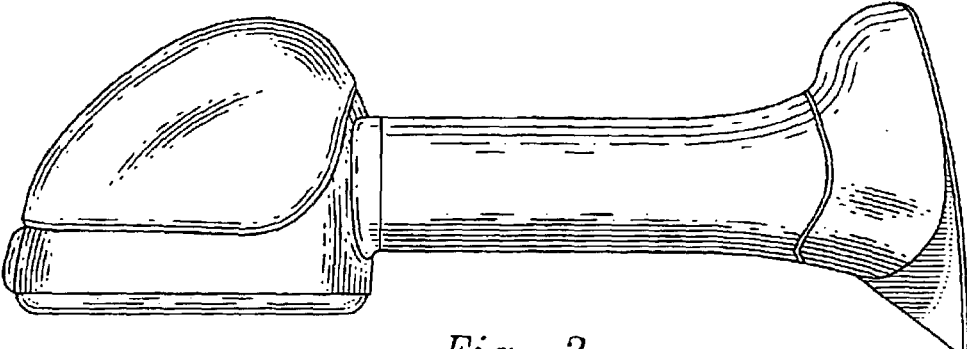

Fig. 3

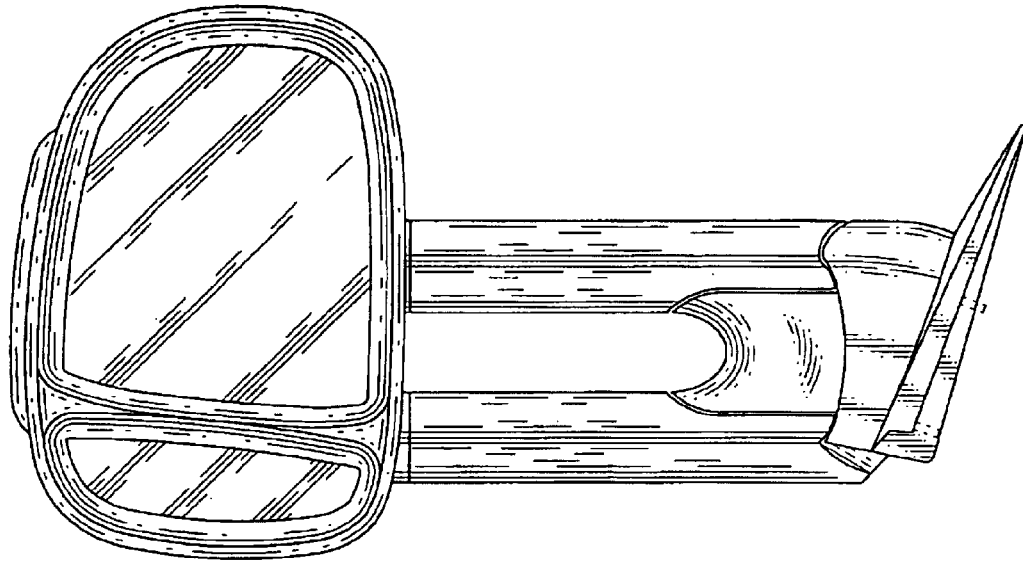

Fig. 4

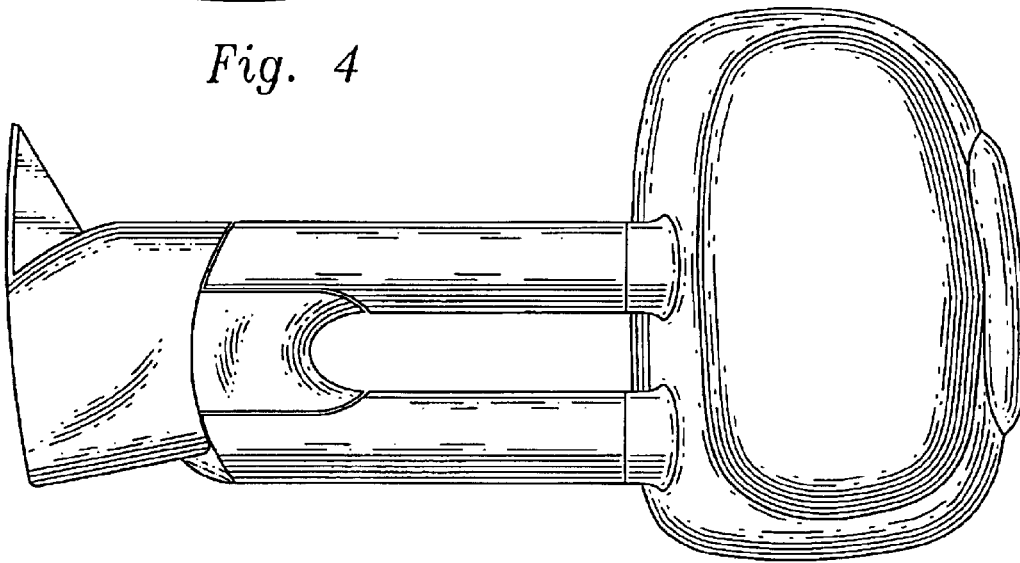

Fig. 5

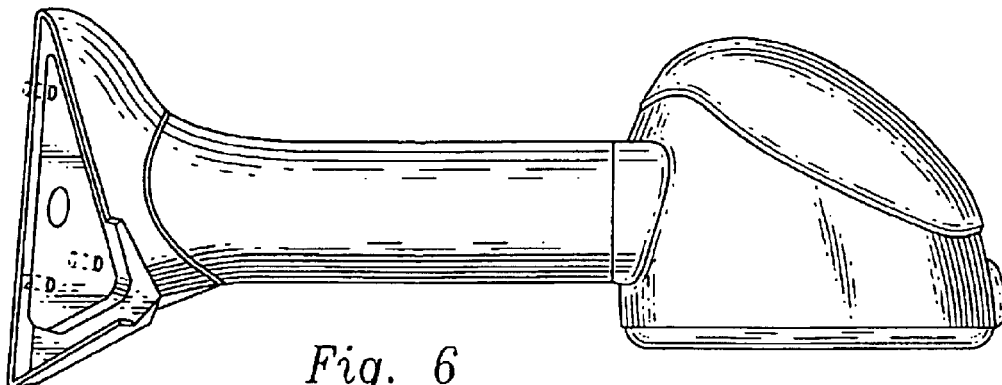

Fig. 6

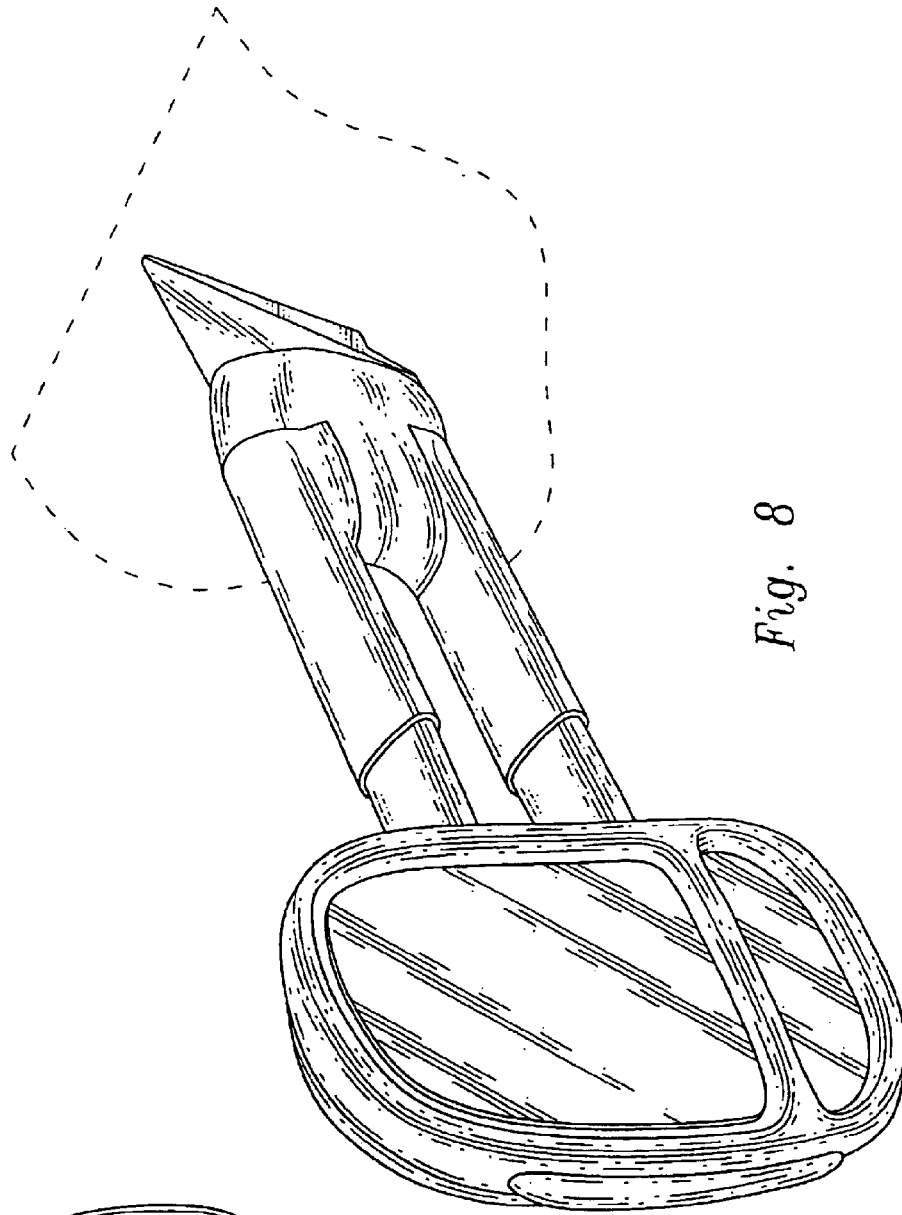

Fig. 8

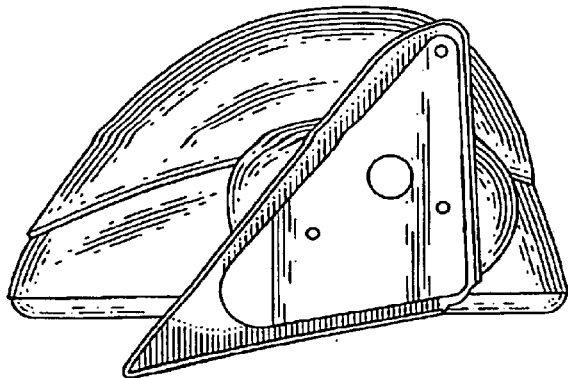

Fig. 7

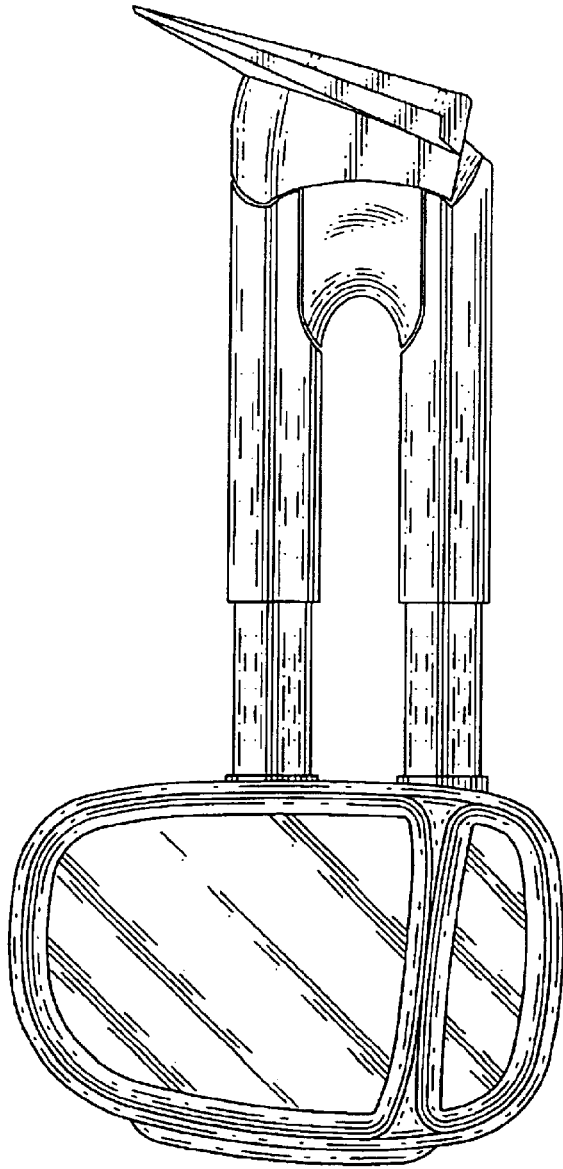

Fig. 9



Fig. 10