



US005873758A

United States Patent [19]

[11] Patent Number: **5,873,758**

Mullins

[45] Date of Patent: **Feb. 23, 1999**

[54] WATER SKI HANDLE

[57] ABSTRACT

[76] Inventor: **Devan M. Mullins**, 400 Capitol Mall, #900, Sacramento, Calif. 95814

A water ski handle **10** is provided which exhibits a high level of rigidity and strength such that the water ski handle **10** does not deform significantly even when experiencing high loads during use. The water ski handle **10** includes a rigid frame **20** of generally triangular construction. The frame **20** includes an apex bend **22** to which a ski rope **R** is attached and a left bend **24** and right bend **26**. A base section **30** extends between the left bend **24** and right bend **26** and provides a region for grasping by a hand **H** of a skier. A left section **34** and right section **37** extend rigidly forward from the base section **30** at opposite ends thereof to the apex bend **22**. The frame **20** is constructed with a low density polymeric foam core **60** with longitudinal fibers **70** surrounding the foam core **60** and helical fibers **80** and perpendicular fibers **86** surrounding the longitudinal fibers **70** with all of the fibers **70, 80, 86** embedded within an epoxy resin matrix **90**.

[21] Appl. No.: **903,613**

[22] Filed: **Jul. 31, 1997**

[51] Int. Cl.⁶ **A63C 15/06**

[52] U.S. Cl. **441/69**

[58] Field of Search 441/69; D21/230

[56] **References Cited**

U.S. PATENT DOCUMENTS

3,861,347	1/1975	Christenson	441/69
4,863,407	9/1989	Casad	441/69
4,895,538	1/1990	Marks	441/69
5,453,032	9/1995	Crowe	441/69
5,503,580	4/1996	McCarthy	441/69

Primary Examiner—Jesus D. Sotelo
Attorney, Agent, or Firm—Heisler & Associates

22 Claims, 1 Drawing Sheet

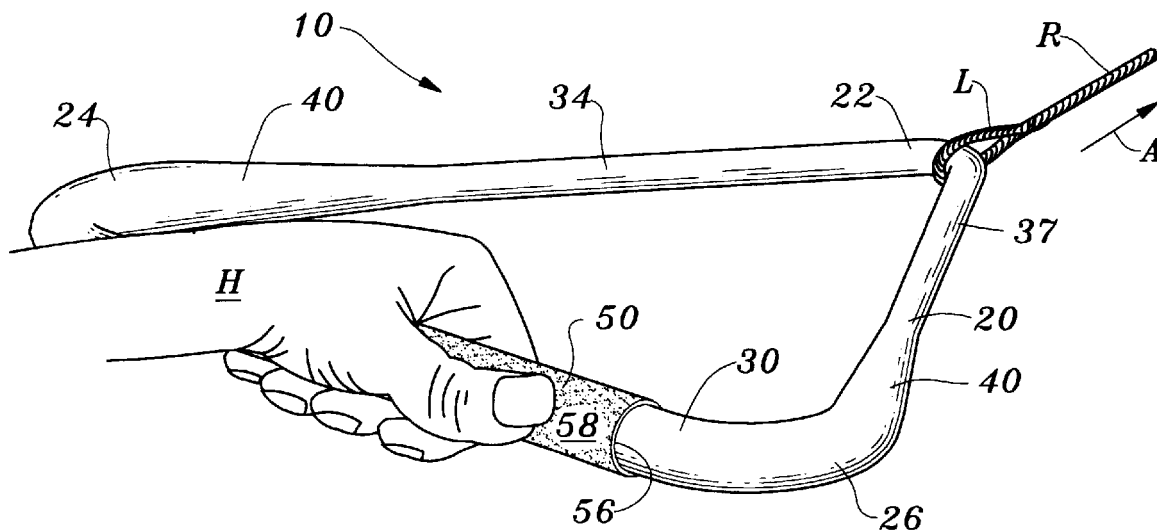

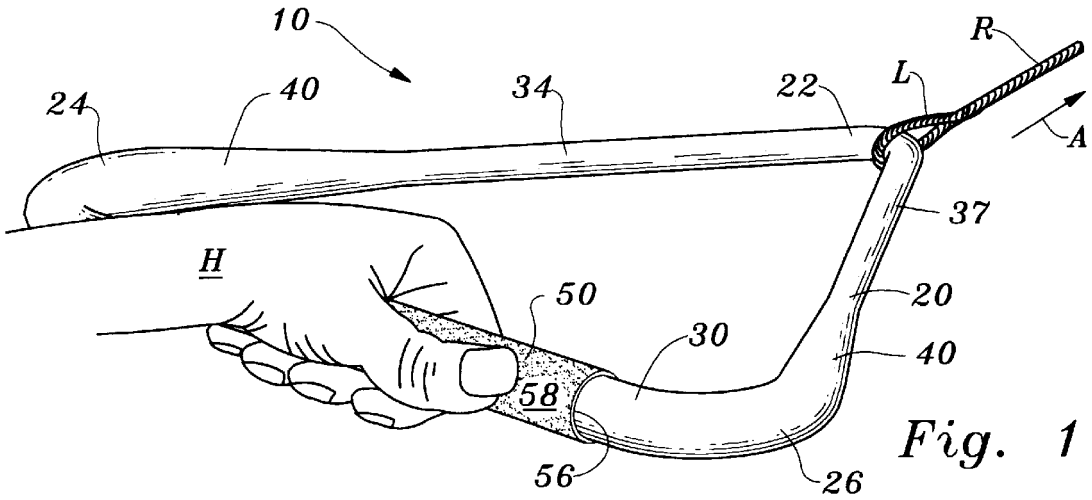

Fig. 1

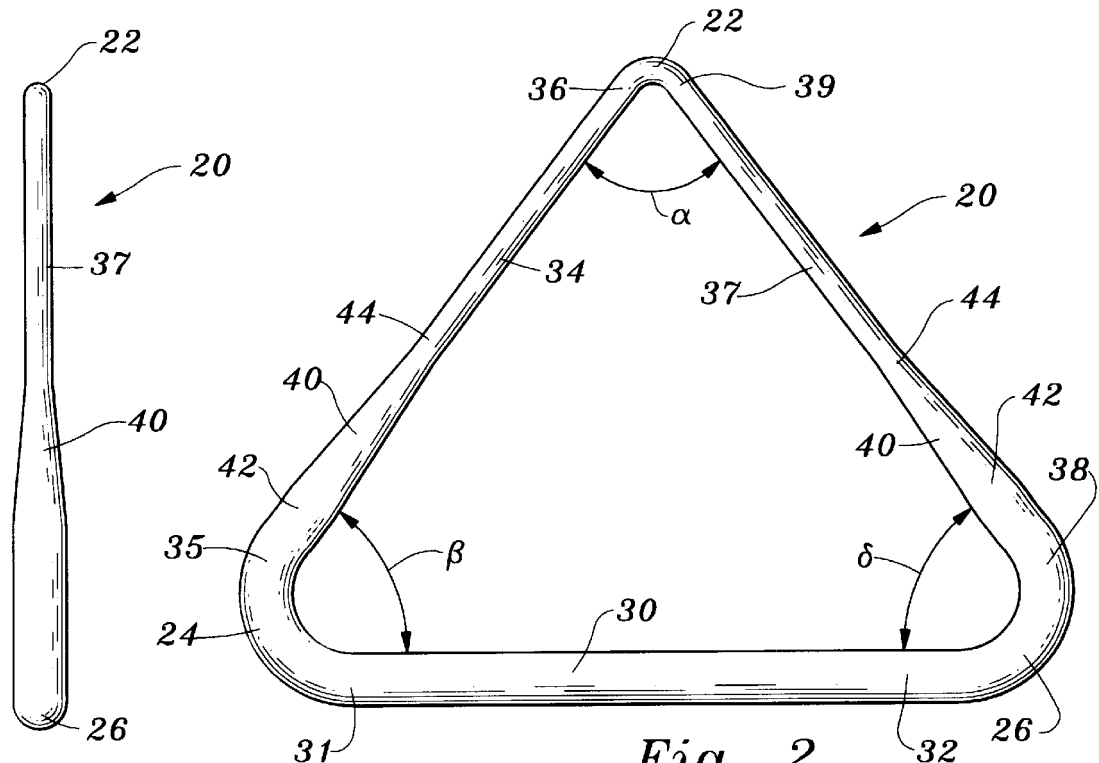

Fig. 2

Fig. 3

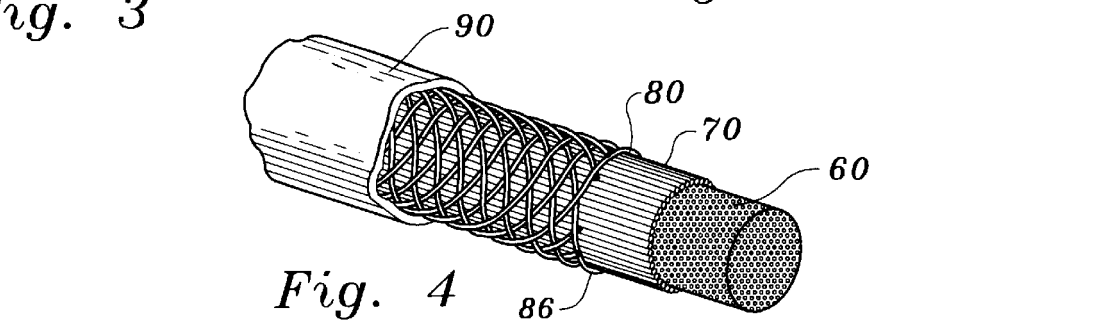

Fig. 4

WATER SKI HANDLE

FIELD OF THE INVENTION

The following invention relates to handles attachable to water ski ropes for towing a water skier behind a boat or other water craft. More specifically, this invention relates to water ski handles which are light weight and of rigid high strength construction.

BACKGROUND OF THE INVENTION

Water skiing involves a boat or water craft which pulls a skier over the surface of the water. The skier is typically pulled behind the boat by a tow rope with one end attached to the boat and the other end with a handle for the skier to grasp. In recent years, the sport has benefited from the use of a rigid boom which projects from the side of the boat. The skier may ski next to the boat holding on to the boom or with a short length of rope and handle tied to the end of the boom. Using a boom permits the skier to ski on water undisturbed by the boat wake and allows for easier communication between the skier and the boat.

Water skiing generally involves the use of various types of equipment including a water ski or other device which the skier rides across the surface of the water, a personal flotation device, wet suit or ski gloves. In some instances the skier rides across the surface of the water on their feet or body, a sport which is generally known as barefoot water skiing. For most water skiing, the skier uses a tow rope with a handle at the end of the rope. In some instances, skiers release one or both hands from the handle when skiing, most often while performing tricks or maneuvers.

Water ski tow ropes come in a variety of lengths and are made from various materials. The most common ropes are made of a plastic material such as polypropylene, polyethylene or Kevlar. Ropes with less elongation are preferred because they allow the skier better control. One end of the rope usually has a loop for attachment to a secure part of the boat. The other end of the rope typically has a handle which is grasped by the skier. The loads on water ski ropes and handles can be quite significant when used by high performance slalom water skiers, barefoot water skiers, and those engaged in competition.

Typical prior art water ski handles include a single cylindrical linear bar which has a rope passing through the center or with rope attachments at either end, with both ends of the rope tied together before attaching to the remainder of the ski line. The bar is typically a hollow tube of aluminum or similar material. In some cases, the ropes that attach to the handle are covered with some type of flotation device to prevent the handle from sinking in the water and to protect the skier from injury. These rope segments which attach to the handle are generally quite flexible.

Prior art water ski handles suffer from a variety of drawbacks including rope stretch, handle deformation, distortion, breakage, excessive weight and limited flotation. Skiers generally prefer that the ski rope and handle be as inelastic as possible under tension loads and when grasping or releasing the handle during use. Minimizing these drawbacks enhances the skier's ability to perform in an optimal manner. Accordingly, a need exists for a rigid, lightweight ski handle which eliminates the handle ropes, strengthens other portions of the handle and floats.

SUMMARY OF THE INVENTION

This invention provides a water ski handle which is rigid and maintains its form very precisely under a wide range of

different loads experienced during towing of a water skier. The ski handle includes a somewhat triangular frame with a base section to which a coating is applied to provide a hand grasping area for the hands of a water skier and a rigid left section and rigid right section extending from ends of the base section up to an apex where the left section and the right section join together. The apex provides a location at which a tow rope can be attached to the handle. A left bend and a right bend are provided on sides of the base section adjacent to the left section and right section respectively. These bends, along with the apex bend, rigidly attach the base section to the left section and the right section. Thus, the entire frame is a single rigid construct.

The frame of the water ski handle is constructed with a cylindrical foam core with fibers surrounding the core and embedded within a matrix of material which can be applied to the fibers in liquid form and then harden into a solid matrix in which the fibers are embedded. The fibers are oriented both longitudinally and helically with respect to the central axis of the cylindrical core to provide strength to the frame sufficient to resist tension, compression, bending and torsional loads on the frame.

OBJECTS OF THE INVENTION

Accordingly, a primary object of the present invention is to provide a water ski handle for a water ski tow rope which rigidly extends from a hand grasping base portion thereof to an apex portion at which the tow rope is connected to the handle.

Another object of the present invention is to provide a water ski handle which does not flex when provided with tension loads similar to those encountered when a water skier is towed by a tow boat.

Another object of the present invention is to provide a water ski handle which is sufficiently light weight to float in water.

Another object of the present invention is to provide a water ski handle which does not include any connectors, but rather is a single unitary mass.

Another object of the present invention is to provide a water ski handle which enhances the ability of a water skier to feel the actions of the tow boat to which a rope of the water ski handle is attached.

Another object of the present invention is to provide a water ski handle which can be readily manufactured from high strength light weight materials to provide the water ski handle with the desired performance characteristics.

Other further objects of the present invention will become apparent from a careful reading of the included description, the claims and included drawing figures.

BRIEF DESCRIPTION OF THE DRAWING FIGURES

FIG. 1 is a perspective view of the water ski handle of this invention in use connected to a water ski tow rope and grasped by a hand of a water skier.

FIG. 2 is a top plan view of a frame portion of the water ski handle of this invention.

FIG. 3 is a right side view of that which is shown in FIG. 2.

FIG. 4 is a perspective view of a portion of the frame of the water ski handle with different layers included in the construction of the frame peeled away to reveal interior details of the frame of the water ski handle.

DETAILED DESCRIPTION OF THE PREFERRED EMBODIMENT

With reference to the drawings, wherein like reference numerals represent like parts throughout the various different drawing figures, reference numeral **10** is directed to a water ski handle exhibiting high rigidity and light weight construction. The water ski handle **10** is attachable to a rope **R** which in turn is connectable to a water ski tow boat such that forces are applied along the rope **R** along arrow **A**. A coating **50** applied to a frame **20** of the water ski handle is graspable by a hand **H** of a water skier such that the water skier can be towed by a water ski tow boat through the rope **R** and water ski handle **10**.

In essence, and with particular reference to FIG. 1, the general features of the water ski handle **10** are provided. The water ski handle **10** includes a rigid frame **20** of generally triangular configuration with a coating **50** on a base section **30** of the frame **20**. The triangular frame **20** includes a linear left section **34** and linear right section **37** extending from ends of the base section **30** forward to an apex bend **22** where the left section **34** and right section **37** are joined together. A left bend **24** is interposed between the left section **34** and the base section **30** and a right bend **26** is interposed between the right section **37** and the base section **30**. Thus, the apex bend **22**, left bend **24** and right bend **26** form the three corners of the triangular frame **20** and the base section **30**, left section **34** and right section **37** provide the three sides of the triangular frame **20**. The base section **30** exhibits a greater diameter than the left section **34** and right section **37** with a transition **40** provided between ends of the base section **30** and the left section **34** and right section **37** to alter the diameter of the frame **20** there between.

The frame **20** is constructed with a solid cylindrical foam core **60** (FIG. 4) which is surrounded by longitudinal fibers **70** extending parallel to a central axis of the foam **60**. Helical fibers **80** are wound helically around the longitudinal fibers **70** and around the foam **60**. Some of the helical fibers **80** are oriented as perpendicular fibers **86** which wind helically about the longitudinal fibers **70** and foam **60** in an orientation perpendicular to the helical fibers **80**. The fibers **70**, **80**, **86** are all embedded within an epoxy resin matrix **90** securing the fibers **70**, **80**, **86** to the foam **60**. A coating **50** surrounds an outer surface of the base section **30** of the frame **20** and provides a region of enhanced coefficient of friction to allow a skier to more easily grasp the water ski handle **10** with a hand **H**.

More specifically, and with particular reference to FIGS. 2 and 3, details of the frame **20** are provided. The frame **20** is generally triangular when viewed from above and generally circular when viewed in section taken anywhere along the frame **20**. The frame **20** is hollow in a middle region thereof such that the frame **20** actually only provides a perimeter of a hollow triangle, rather than a solid. However, within the circular cross-section of the frame **20**, as it traces the perimeter of a triangle, the frame **20** is preferably solid and composed of a variety of different structures as discussed below.

The frame **20** thus includes three corners and three sides. The three corners are provided as an apex bend **22**, a left bend **24** and a right bend **26**. The three sides are provided as the base section **30**, the left section **34** and the right section **37**. Each of the sections **30**, **34**, **37** is a cylindrical linear rigid construct. Each of the bends **22**, **24**, **26** does not provide a sharp corner, but rather is radiused.

The triangular shape of the frame **20** is preferably an isosceles triangle with the base section **30** being slightly

longer than the left section **34** and the right section **37**. Alternatively, the base section **30** could be shorter than or equal to the length of the left section **34** and the right section **37**. The left section **34** and right section **37** are preferably similar in length. Similarly, the apex bend **22** has an angle slightly greater than the left bend **24** and right bend **26**. Specifically, an apex angle α preferably has a measure of between 60° and 80° , and optimally 70° . A left bend angle β is preferably equal to a right bend angle δ and measures between 50° and 60° , and optimally 55° . The apex bend **22** is preferably radiused such that an inside of the apex bend has a radius of curvature of $\frac{5}{16}$ of an inch when the overall width of the entire frame **20** from the left bend **24** to the right bend **26** measures twelve inches and an overall height of the frame **20** from the base section **30** to the apex bend **22** measures $10\frac{1}{4}$ inches. Preferably, the left bend **24** and right bend **26** are provided with an inside radius of curvature of one inch. Thus, the apex bend **22** is slightly more sharply radiused than is the left bend **24** and right bend **26**.

The base section **30** is a cylindrical linear rigid section extending from a left end **31** to a right end **32**. The left end **31** is adjacent the left bend **24** and the right end **32** is adjacent the right bend **26**. The left section **34** is cylindrical but includes two different portions including a purely cylindrical portion and a transition **40** which is actually frustoconical and tapered somewhat. The left section **34** includes a rear end **35** adjacent the left bend **24** and a front end **36** adjacent the apex bend **22**. The rear end **35** of the left section **34** includes the transition **40** adjacent thereto.

The transition **40** preferably extends for three inches from a large end **42** adjacent the left bend **24** to a narrow end **44** closer to the apex bend **22** than is the large end **42**. The remainder of the left section **34** from the transition **40** up to the apex bend **22** preferably has a constant diameter which preferably measures $\frac{7}{16}$ of an inch. The large end **42** of the transition **40** preferably has a diameter of $\frac{7}{8}$ of an inch. Thus, the transition **40** alters the diameter of the left section **34** from $\frac{7}{8}$ of an inch adjacent the large end **42** to $\frac{7}{16}$ of an inch adjacent the narrow end **44**.

The right section **37** is a mirror image of the left section **34**. Thus, the right section **37** includes a back end **38** adjacent the right bend **26** and a forward bend **39** adjacent the apex bend **22**. The right section **37** also includes a transition **40** thereon similar to the transition **40** in the left section **34**. The base section **30** preferably has a diameter of $\frac{7}{8}$ of an inch, with this diameter of the base section **30** remaining constant through both the left bend **24** and right bend **26** and up to the large end **42** of each transition **40**.

The apex bend **22** preferably maintains a diameter throughout the apex bend **22** of $\frac{7}{16}$ of an inch, such that the frame **20** maintains a constant diameter from the left bend **24** over to the right bend **26**, through the apex bend **22**. Thus, the cross-sectional diameter of the frame **20** is either $\frac{7}{8}$ of an inch or $\frac{7}{16}$ of an inch except where the transitions **40** are oriented and the frame **20** transitions from $\frac{7}{8}$ of an inch down to $\frac{7}{16}$ of an inch.

The larger diameter of the base section **30** makes the base section **30** most easily graspable by most hand sizes. The smaller diameter of the left section **34** and right section **37** provides sufficient structure to maintain the rigidity of the frame **20** but allows non-grasped portions of the frame **20** to exhibit a smaller size and hence a lighter weight. The radii of curvature for the left bend **24** and right bend **26** and the apex bend **22** are provided to be sufficiently gradual to avoid concentration of stresses at the bends **22**, **24**, **26** and to provide a smooth transition between the various different

sections **30**, **34**, **37** of the frame **20**. However, various different radii of curvature could be utilized with slight alterations resulting in performance of the water ski handle **10**.

The base section **30** includes the coating **50** thereon. Preferably, the coating **50** is a material which can be applied in a liquid form but then solidify into a solid form upon either drying or receiving a heat or other fixation treatment. The coating **50** preferably only extends along the base section **30** between the left bend **24** and right bend **26**, so that the coating **50** is purely a hollow cylindrical layer surrounding a linear central section of the base section **30**. The coating **50** includes an inner side **56** adjacent the base section **30** and an outer surface **58** opposite the inner surface **56**. The outer surface **58** preferably exhibits a coefficient of friction which is greater than that exhibited by the base section **30** and other portions of the frame **20**. Thus, the ability of the water ski handle **10** to be readily grasped by a skier is enhanced adjacent the coating **50**.

With particular reference to FIG. 4, details of the construction of the frame **20** are provided. The frame **20** is preferably of a composite construction with different materials making up different layers within the frame **20**. At a center of the frame **20**, preferably along all of the various different portions of the frame **20**, a cylindrical core **60** is provided. This core is preferably formed from a low density polymeric foam. Thus, the foam **60** adds minimal weight to the water ski handle **10** and provides a cylindrical surface upon which other layers of the water ski handle **10** can be applied during construction. Additionally, the foam **60** resists incursion of water and other liquids into an interior of the frame **20**, should a crack or other hole form passing into an interior of the frame **20**. The foam **60** thus enhances the buoyancy of the water ski handle **10**.

The foam **60** typically is formed from a material which does not have significant rigidity characteristics. Such rigidity is provided by fibers **70**, **80**, **86** surrounding the foam **60**. Preferably, the fibers **70**, **80**, **86** are oriented in three distinct orientations. The first orientation provides longitudinal fibers **70** extending parallel to a long axis of the cylindrical foam core **60** in an orientation such that each longitudinal fiber **70** is adjacent other longitudinal fibers **70** so that the longitudinal fibers **70** entirely surround the foam core **60**.

The fibers **70**, **80**, **86** are generally selected from a material which has little or no elasticity when loaded in tension along a length of the fibers **70**, **80**, **86**. For instance, if the fibers are formed from carbon or carbon composite materials such that the fibers **70**, **80**, **86** are carbon fibers, the longitudinal fibers **70** will exhibit essentially no elongation when loaded along a length of the frame **20** parallel to the long axis thereof. Another material having desirable rigidity and density for the frame **20** is Kevlar.

However, the longitudinal fibers **70** do not provide torsional load deformation resistance or significant bending load resistance. Hence, helical fibers **80** are provided wrapping helically around the longitudinal fibers **70** and the foam core **60**. Preferably, the helical fibers **80** are paired up with perpendicular fibers **86** which also wrap helically about the longitudinal fibers **70** and foam core **60** but in an orientation perpendicular to the helical fibers **80**. The helical fibers **80**, **86** provide enhanced strength to the frame **20** to resist bending and torsional loads experienced thereby. However, the helical fibers **80** and perpendicular fibers **86** do not significantly resist tension loads along a central axis of the cylindrical foam **60**. Thus, the helical fibers **80** and perpendicular fibers **86** benefit from the presence of the longitudi-

nal fibers **70** and their resistance to longitudinal deformation. Considered together, the fibers **70**, **80**, **86** provide high rigidity and resistance to longitudinal, torsional and bending loads which the frame **20** might experience.

To prevent motion of the fibers **70**, **80**, **86** relative to each other and to prevent damage to individual fibers, the fibers **70**, **80**, **86** are embedded within an epoxy resin matrix **90**. Such a matrix is generally a material which exhibits two different phases including a liquid phase during a formation stage which can then harden into a solid phase when desired. Preferably, the resin is in liquid form when it is embedded into the area between the fibers **70**, **80**, **86** by techniques such as pressurizing the liquid resin when it is applied to the fibers **70**, **80**, **86**. The resin **90** is then allowed to harden into position, encasing the fibers **70**, **80**, **86** and the foam **60** within the resin.

While preferably the foam core **60** extends entirely around the triangular frame **20**, alternatively, the foam core **60** can be provided merely along the base section **30**. In such a configuration, other portions of the frame **20** can be allowed to remain hollow or can be merely filled with the epoxy resin matrix during the manufacturing procedure.

The fibers **70**, **80**, **86** can either be wound individually around the foam core **60** or can be provided as a fabric having the desired weave pattern to provide longitudinal fibers **70**, helical fibers **80** and perpendicular fibers **86**. Such fabrics could either be provided with separate layers or as a single fabric with all of the separate layers included therein. For instance, one layer could be provided which includes longitudinal fibers embedded within a matrix and perpendicular fibers embedded within a matrix. The longitudinal fabric would then be wrapped around the foam core **60** in a manner providing the longitudinal fibers **70** in the desired orientation. The helical fibers **80** and perpendicular fibers **86** would then be wrapped around the longitudinal fibers **70** by placing the fabric having the helical fibers **80** and perpendicular fibers **86** overlying the fabric including the longitudinal fibers **70** with the helical fibers **80** and perpendicular fibers **86** in the desired orientation.

If desired, multiple layers of longitudinal fibers **70** and helical fibers **80** can be provided in either alternating layers or in consecutive layers. Similarly, the fibers **70**, **80**, **86** can all be woven together in an integrated fashion. In general, as additional layers of fibers **70**, **80**, **86** are provided, an overall strength of the frame **20** and hence the water ski handle **10** is enhanced, as well as a rigidity of the water ski handle **10**.

After the epoxy resin matrix **90** has become fixed in solid form, the coating **50** is preferably applied to the base section **30** of the frame **20** to complete the water ski handle **10**. The water ski rope R can then be attached to the water ski handle **10** adjacent the apex bend **22** by providing a loop L in the rope R or some knot or other feature in the rope R to wrap around the apex bend **22**. The water ski handle **10** can then be utilized in the same manner as prior art water ski handles, except that the water ski handle **10** exhibits a high level of rigidity and light weight characteristics for high performance operation.

Moreover, having thus described the invention it should be apparent that various different modifications could be made to the invention without significantly altering the characteristics exhibited thereby. For instance, while carbon fiber has been indicated as a preferred material for formation of the water ski handle **10**, various different materials including fiberglass or plastics or other composite materials could similarly be utilized and still benefit from many of the features disclosed herein. While the preferred angles and

radiuses and diameters of the triangular frame **20** have been specifically identified, different adjustments could be made thereto to accommodate skiers having different hand H sizes, strengths or desires for the performance of the handle **10**, resulting in the alteration of these dimensions somewhat.

It is also understood that while the frame **20** is shown to have a generally triangular configuration, the frame **20** need only have the base section **30** provided in an orientation generally perpendicular to that of a region of the frame **20** to which the rope R is attached. Thus, the frame **20** could for instance be pentagonal and still provide an apex bend directly opposite a base section to which a handle grasping area could be provided. Also, lengths of various different sections **30**, **34**, **37** of the water ski handle **10** could be increased or decreased if desired. While it is preferred that the water ski handle **10** be a closed loop for maximum rigidity, it could also be possible that the apex bend **22** could be removed and the left section **34** and the right section **37** could extend rigidly forward and then transition into the tow rope R by providing various different connectors to both the left section **34** and right section **37**, provided that the right section **37** and left section **34** rigidly connect to the base section **30** and extend forward from the left end **31** and right end **32** of the base section **30**.

What is claimed is:

1. A water ski handle for attachment to a water skiing tow rope, the handle comprising in combination:

a rigid cylindrical base section extending linearly between a left end and a right end;

a left bend rigidly formed with said base section and bending forward away from a central axis of said base section;

a right bend rigidly formed with said base section and bending forward away from said central axis of said base section;

said left bend and said right bend including means to attach to the water skiing tow rope;

wherein said left bend extends rigidly forward as an elongate left section and said right bend extends rigidly forward as an elongate right section, said left section and said right section each supporting said means to attach to the rope;

said left section and said right section formed from a rigid material;

wherein said left section includes a front end opposite said left bend and said right section includes a forward end opposite said right bend, said front end of said left section rigidly attached to said forward end of said right section at an apex, said apex including said means to attach to the rope;

wherein said left section and said right section extend linearly from said base section to said apex, said left section and said right section each having a circular cross-section; and

wherein said means to attach to the rope provided by said apex includes the rope being looped around said apex such that at least a portion of the rope passes between said apex and said base section, between said left section and said right section.

2. The water ski handle of claim **1** wherein said left section and said right section are of equal length and wherein said left section, said right section and said base section together form a triangle.

3. The water ski handle of claim **2** wherein said base section has a diameter which is greater than a diameter of

said left section and said right section and wherein said left section and said right section have substantially equal diameters.

4. The water ski handle of claim **3** wherein said left section extends away from said left bend at an angle to said base section which matches an angle between said base section and said right section as said right section extends away from said right bend, such that said triangle formed by said left section, said right section and said base section is an isosceles triangle.

5. A water ski handle for attachment to a water skiing tow rope, the handle comprising in combination:

a rigid cylindrical base section extending linearly between a left end and a right end;

a left bend rigidly formed with said base section and bending forward away from a central axis of said base section;

a right bend rigidly formed with said base section and bending forward away from said central axis of said base section;

said left bend and said right bend including means to attach to the water skiing tow rope;

wherein said rigid cylindrical base section said left bend and said right bend are each formed from materials including a plurality of substantially inextensible elongate fibers;

wherein at least one of said elongate fibers is a parallel fiber oriented substantially parallel to said central axis of said base section and at least one of said fibers is a helical fiber oriented in a position revolving helically around said central axis of said base section; and

wherein at least one of said fibers is a counter fiber oriented in a position revolving helically around said central axis of said base section in a direction counter to a direction of helical rotation of at least one of said helical fibers forming said water ski handle.

6. The water ski handle of claim **5** wherein at least a portion of said fibers forming said base section and said left bend and said right bend are carbon fibers and wherein at least a portion of said fibers forming said base section are made of Kevlar;

wherein a surface of said base section includes a coating thereon, said coating formed from a material having a greater coefficient of friction than a coefficient of friction exhibited by other portions of said base section, such that an ability of a user to grip said base section through said coating is enhanced; and

wherein said fibers of said base section are wrapped around an exterior of a foam core, said foam core having a density sufficiently less than a density of water that said water ski handle floats when located in water.

7. A rigid water skiing tow rope handle, comprising in combination:

a rigid cylindrical base section extending linearly between a left end and a right end;

a left bend rigidly formed with said base section and bending forward away from a central axis of said base section;

a right bend rigidly formed with said base section and bending forward away from said central axis of said base section;

a rigid left section rigidly attached to said left bend and extending forward to an apex;

a rigid right section rigidly attached to said right bend and extending forward to said apex;

9

said apex rigidly joining said left section and said right section together;

said handle including a plurality of elongate substantially inextensible fibers; and

wherein at least one of said elongate fibers is a longitudinal fiber, said longitudinal fiber oriented parallel to said central axis of said base section, said elongate fibers including at least one helical fiber extending helically around said central axis of said base section, said elongate fibers including at least one counter rotating fiber, said counter rotating fiber oriented helically around said central axis of said base section in a direction counter to a direction of rotation of said helical fiber around said central axis of said base section.

8. The tow rope handle of claim 7 wherein said left section and said right section extend linearly between said base section and said apex, said left section and said right section having a circular cross-section, said left section and said right section integrally formed with each other and with said base section, said left section and said right section including said longitudinal fibers, said helical fibers and said counter fibers.

9. The tow rope handle of claim 7 wherein said elongate fibers are supported within a solid matrix, said matrix fixing said elongate fibers in a constant orientation relative to said base section, said left section and said right section.

10. The tow rope handle of claim 9 wherein said elongate fibers are formed from materials taken from the group of materials including carbon fibers and Kevlar fibers; and wherein said matrix includes a liquid resin which hardens into a solid material.

11. The tow rope handle of claim 9 wherein said base section includes a cylindrical foam core aligned with said central axis of said base section, said elongate fibers located beyond an exterior surface of said cylindrical foam core, said foam core having a density less than a density of water.

12. The tow rope handle of claim 11 wherein said foam core is sealed to preclude water from being absorbed therein and said tow rope handle has an overall density less than a density of water, such that said tow rope handle floats when placed in water.

13. The tow rope handle of claim 10 wherein said base section includes a coating on an outermost surface of said base section, said coating formed from a material having a coefficient of friction which is greater than a coefficient of friction of materials forming portions of said base section adjacent said coating.

14. A method for forming a water skiing tow rope handle, including the steps of:

providing a cylindrical elongate piece of solid foam;
applying elongate substantially inextensible fibers to an outer surface of the foam cylinder;

10

extending elongate substantially inextensible fibers away from both ends of the foam cylinder to an apex forward of the foam cylinder;

applying a liquid resin matrix to the elongate fibers;

allowing the liquid resin matrix to harden into a solid; and attaching a tow rope to the apex.

15. The method of claim 14 including the further steps of: selecting the elongate fibers to be formed from materials taken from a group of materials including carbon fibers and Kevlar fibers;

pressurizing the liquid resin matrix after the liquid resin matrix is applied to the elongate fibers and before hardening of the liquid resin matrix;

shaping the elongate fibers to extend linearly as a left section and a right section away from the ends of the foam core and toward the apex; and

orienting some of the elongate fibers to wrap helically around a central axis of the foam core and orienting some of the elongate fibers to extend longitudinally parallel to the central axis of the foam core.

16. A water ski handle for attachment to a water skiing tow rope, the handle comprising in combination:

an elongate base section extending substantially linearly between a left end and a right end;

an elongate left section attached to said left end of said base;

an elongate right section attached to said right end of said base;

an apex joining said left section to said right section such that said base section, said left section and said right section together form a continuous loop; and

said continuous loop being rigid.

17. The handle of claim 16 wherein said rope is attached to said apex by being looped around said apex such that at least a portion of said rope passes between said apex and said base section at a location surrounded by said continuous loop.

18. The handle of claim 16 wherein said handle has a lower density than water, such that said handle floats in water.

19. The handle of claim 16 wherein said apex is V-shaped with said elongate left section forming one leg of said V and said elongate right section forming the other leg of said V.

20. The handle of claim 19 wherein said V of said apex has an internal angle measuring less than 90°.

21. The handle of claim 16 wherein a core within said base section, said left section and said right section is solid.

22. The handle of claim 16 wherein a core of said base section, said left section and said right section is ropeless.

* * * * *